

BRICKS FOR JUSTICE, A TRAVELING EXHIBITION  
FOR INTERNATIONAL JUSTICE MISSION,  
A HUMAN RIGHTS ORGANIZATION

THESIS

Presented to the Graduate Council of  
Texas State University-San Marcos  
in Partial Fulfillment  
of the Requirements

for the Degree

Master of FINE ARTS

by

Genaro Solís Rivero, B.F.A.

San Marcos, Texas  
August 2012

BRICKS FOR JUSTICE, A TRAVELING EXHIBITION  
FOR INTERNATIONAL JUSTICE MISSION,  
A HUMAN RIGHTS ORGANIZATION

Committee Members Approved:

---

Claudia Roeschmann, Chair

---

Jeffrey G. Davis

---

Maia Wright

Approved:

---

J. Michael Willoughby  
Dean of the Graduate College

**COPYRIGHT**

by

Genaro Solís Rivero

2012

## **FAIR USE AND AUTHOR'S PERMISSION STATEMENT**

### **Fair Use**

This work is protected by the Copyright Laws of the United States (Public Law 94-553, section 107). Consistent with fair use as defined in the Copyright Laws, brief quotations from this material are allowed with proper acknowledgment. Use of this material for financial gain without the author's express written permission is not allowed.

### **Duplication Permission**

As the copyright holder of this work I, Genaro Solís Rivero, refuse permission to copy in excess of the "Fair Use" Exemption without my written permission.

## **DEDICATION**

This thesis is dedicated to all the children and former victims that have suffered the burden of oppression and injustice, and to all the IJM staff and volunteers, for their great example of servitude.

In addition, I would also like to dedicate this thesis to my wife, Maria Fernanda, for her unconditional love, for never allowing me to give up, for being my daily inspiration, and for her infinite patience; to my mother, Virginia, who raised me, gave me a fine education, and taught me to care for others; to my father, Genaro, for his example of hardworking and entrepreneurship; to my sisters, Virginia and Ivonne, for being always present, supportive, and full of joy; my aunt Anna, for her relentless encouragement; and to my brother-in-law and friend Scott, for his honest and true friendship.

Finally, I would like to dedicate this thesis to my in-laws, Elvira, Luis, and Don Marco, for their unconditional support, love, and wise advice.

This is the result of all the effort, support, and commitment of all of you.

## ACKNOWLEDGEMENTS

“Be thankful in all circumstances, for this is God's will for you who belong to Christ Jesus” (1 Thessalonians 5:18, New Living Translation).

I would like to thank the faculty and staff of the Communication Design M.F.A. program for their encouragement, advice, and guidance. Especially, I would like to thank Christine Haney, for all her support and eagerness to go above and beyond to help me in any way she could.

I am indebted to my thesis committee members, Jeffrey G. Davis and Maia Wright, for their patience, professional expertise, unwavering support, and sound advice.

Additionally, I would like to thank Claudia Roeschmann, for accepting to chair my thesis committee, for pushing me relentlessly and always expecting perfection, for her willingness to share her passion for typography, for her honest commitment, and for her invaluable mentorship.

Finally, I would like to thank Bill Meek, for envisioning the M.F.A. program, for his continuing sound mentorship and friendship, for his teaching, and for always transmitting his unrelenting desire to continue learning.

For all your influence and words of encouragement, thank you!

This manuscript was submitted on April 30, 2012.

## TABLE OF CONTENTS

	<b>Page</b>
ACKNOWLEDGEMENTS .....	vi
LIST OF FIGURES .....	x
CHAPTER	
I. INTRODUCTION .....	1
International Justice Mission .....	1
IJM History .....	1
Human Trafficking.....	2
Brand Experience and Corporate Identity.....	2
Exhibition Design .....	3
II. PRELIMINARY RESEARCH.....	4
Brand Identity .....	5
Brand Experience.....	5
Traveling Exhibition .....	5
Emotional Branding.....	6
Guerrilla advertising .....	7
Responsible design.....	7
III. OUTCOME RATIONALE.....	10
Brand Identity .....	10

Traveling Exhibition .....	10
Guerrilla Advertising Installations.....	13
IV. CONCLUSION.....	16
Future Creative Investigations .....	17
APPENDIX A.....	19
IDENTITY OUTCOME .....	22
Proposed Mark .....	24
Brandmark Morphological Approach.....	25
Proposed Signature .....	26
Signature Versions .....	27
Identities Comparison .....	28
Typographic Palette .....	29
Stationary System   Letterhead .....	30
Stationary System   Business Cards and Envelope.....	31
Ephemera .....	32
Digital .....	33
EGD OUTCOME.....	35
Gallery II Floor Plan Schematics .....	37
Bible Verse Schematics (A).....	39
IJM Mission Statement Schematics (B).....	42
Exhibit Title Schematics (C).....	45
Stories Schematics (D).....	47
Statistics 1 Schematics (E).....	53
Statistics 2 Schematics (F).....	55
Julianna’s Story Schematics (G).....	59



The Bricks for Justice Wall Schematics (H).....	62
Former Victims Schematics (I).....	64
Children’s Clothing Schematics (J) .....	68
APPENDIX B .....	70
EXHIBITION PROMOTIONAL MATERIALS .....	70
APPENDIX C .....	72
EXHIBITION PHOTOGRAPHS .....	72
REFERENCES .....	77

## LIST OF FIGURES

<b>Figure</b>		<b>Page</b>
1	Bricks at Entrance of the Exhibition.....	11
2	The BJW Covering a List of Social Problems .....	12
3	Children’s Clothing.....	13
4	Portrait of a Former Victim.....	13
5	GA Installation in Women’s Restroom.....	14
6	GA Installation in Men’s Restroom.....	14
7	The BJW .....	17

## CHAPTER 1

### INTRODUCTION

This research documents the environmental graphic design (EGD) of a traveling exhibition, a new brand identity (BI), and guerrilla advertising (GA) installations. The intent of this research is to raise awareness of International Justice Mission (IJM) mission around the globe; and demonstrates how the communication design discipline (CDD) may have a positive impact in society by provoking a change in human consciousness.

#### International Justice Mission

IJM is a human rights organization that ensures justice for victims of slavery, sexual exploitation, and other forms of violent oppression. IJM works in 13 countries in Asia, Africa, and Latin America rescuing victims, prosecuting perpetrators, and providing aftercare (International Justice Mission [IJM], 2011).

#### IJM History

Gary Haugen, a lawyer working at the United States Department of Justice and the United Nations' Investigator in Charge of the Rwandan Genocide in 1994, founded IJM in 1997, with one objective in mind: to restrain the oppressors harming the vulnerable in countries where abuse of power by authorities was eminent and trained lawyers were required for justice to prevail (IJM, 2012a). According to IJM (2012a) that “violence against the poor is not driven by the overwhelming power of the perpetrators—it is driven by the vulnerability of the victims.” IJM’s strategy is to represent those who

need it and become an advocate of the poor, who are in urgent need. Furthermore, at the IJM's core is a Christian belief to respond to the Bible's call to justice found in Isaiah 1:17: "Learn to do good. Seek justice. Help the oppressed. Defend the cause of orphans. Fight for the rights of widows" (New Living Translation). IJM casework areas are in forced labor slavery, sex trafficking, imprisonment of the innocent, illegal property seizure from orphans and widows, sexual violence, and citizenship rights for Thailand's hill tribes (IJM, 2011).

### Human Trafficking

According to Article 2 of the International Labor Organization Forced Labor Convention No. 29 of 1930, forced labor is defined as: "all work or service that is exacted from any person under the menace of any penalty and for which the said person has not offered himself voluntarily" (Beate, 2008, p. 4). Examples of forced labor can be found in brick kilns, agriculture, mining, food processing, domestic service, factories, restaurants, manufacturers, and the sex industry. In fact, the annual profits generated from human trafficking are estimated to be as high as \$32 billion US dollars (Beate, 2008, p. 7) and it is estimated that there are more than 27 million slaves in the world (Bales, 2004).

### Brand Experience and Corporate Identity

Brand experience is the interaction of an individual with a brand in advertising, identity applications, and branded environments; this interaction is what affects the individual's perception of the brand (Landa, 2008, p. 9). A brand touchpoint is the term for the item or place where interaction with a brand takes place. Moreover, according to Alina Wheeler (2006), a renowned author, speaker, and brand consultant, people like and believe in brands (p. 2). Consequently, to create a positive interaction with a brand, the

brand touchpoints must communicate the desired brand message. “Above all [branding] makes the strategy of the organization visible and palpable for all audiences to see” (Olins, 2010, p. 21).

The most common element within the brand touchpoints is the corporate logo (i.e. logo, mark, or emblem—in the case of IJM). Thus, the corporate logo must communicate the brand’s message because it is the element that makes individuals remember their interaction with companies, individuals, and/or organizations (Airey, 2010, p. 21). A corporate logo must be simple, relevant, distinct, memorable, easy to reproduce, and legible (p. 38).

### Exhibition Design

The individual’s demand for a new brand experience has led brands to expand their brand interactivity beyond the traditional brand touchpoints. In fact, the space and brand experience is just as important as the product, service, or the brand itself (Berger, Lorenc, and Skolnick, 2007, p. 22). The ultimate goal of an exhibition is to engage with the visitor while providing relevant information (Hughes, 2010, p. 34); the Storyline and visitor interactivity have a direct influence on how the exhibition is perceived by the visitor. Therefore, designing an exhibition where the viewer takes a direct role in the development of the story has more impact than a one-way communication channel (de Jong & Kossmann, 2010, p. 78).

## CHAPTER II

### PRELIMINARY RESEARCH

Research is as important as the outcome. First of all, research provides the CDD facts to understand the client's business and to support the proposed solution (Visocky & Visocky, 2006, p. 11). Best practices within the discipline begin with a review of existent client's materials, interview of key staff, and analysis of competitor's material (i.e. literature) (p. 67).

Finally, research provides the CDD evidence of existent visual and strategic solutions to similar communication needs, solutions to be avoided to retain originality and a significant differentiation among the client's competition (Neumeier, 2007, p. 65).

#### Brand Identity

The IJM identity (i.e. emblem) has been used consistently throughout different brand touchpoints; however, it has legibility and reproduction constraints. Additionally, the current IJM identity has a governmental resemblance, which is not recommended for a humanitarian organization especially when IJM works in countries where there is evidence of the involvement of corrupt government officials with social issues IJM constantly confronts (Haugen, 2006, p. 38).

Immediately recognizable forms facilitate brand awareness and brand recognition. Additionally, according to Wheeler (2006), the sequence of cognition states that the human brain first recognizes shape, secondly color, and finally form (p. 52); thus the

importance of IJM's identity to use simple and recognizable shapes.

In sum, an identity needs to communicate one specific message, to be simple in form (i.e. flexible to reproduce) and equally important, to be memorable (i.e. easy to remember) (Kennedy, 2011, p. xii).

### Brand Experience

Equally important to the brand identity is the brand experience, which is the interaction a person has with the brand, which takes place in different brand touchpoints (i.e. advertising, packaging design, corporate communications, museums, or exhibitions). The brand experience is positive or negative and is directly influenced by the interaction a person has with the brand touchpoints (Landa, 2006, p. 9).

Currently, the IJM brand experience is taking place throughout several implemented programs, such as testimonials, success stories, statistics, advocacies, meetings, workshops, internships, fellowships, and corporate marketing materials (IJM, 2012a). The IJM's branded programs' main objectives are to recruit new volunteers, to successfully hold fund-raisers, to raise awareness of IJM's mission, and to report the success of IJM's field operations.

### Traveling Exhibition

During an initial interview, Mr. Andy Hein—the Central South Director of Church Mobilization for IJM—expressed his desire to implement a traveling exhibition to inform and raise awareness of IJM's mission around the globe. Mr. Hein has more than 15 years of experience in leading and motivating church members; he has worked in South Carolina, Ohio, and Texas and has helped churches to implement leadership and engaging plans, all related to missions. Mr. Hein has led mission teams to serve in 30

countries around the world (IJM, 2012a).

An exhibition needs to be integrated into the space; in fact, it is an opportunity to introduce the exhibition to the visitors at different places (Berger, et al. 2007, p. 104). Furthermore, traveling exhibitions are designed to communicate the same message in different settings, while maintaining the same storyline, narrative, and visitor experience (p. 100). Equally important, traveling exhibitions need to be flexible to accommodate different installation sites. However, the graphic elements and style are aligned to the client's brand guidelines to maintain a coherent brand message and to reinforce brand recognition (Hughes, 2010, p. 45).

### Emotional Branding

Emotional branding is a twenty-first century concept that states that economies have changed from factory to consumer based; instead of the economy being focused on production, the consumer is the center of attention (Gobé, 2009, p. xviii). Marc Gobé (2009), an author, human behavior researcher, and worldwide renowned brand consultant, describes emotional branding as “how a brand engages consumers on the level of the senses and emotions” (p. xviii). In fact, emotions are taking an important role on how brands are perceived and experienced by consumers because emotions are the way human brains encode things of value; consequently, the brands engaging the consumer emotionally have an advantage over those brands that do not (Lindstrom, 2008, p. 27).

Even though humans have five different senses, according to Lindstrom (2005), a bestseller author on brands, “touch is the tool of connection” (p. 33). It is by touch that humans feel an inflicted pain and affection (p. 34). Hence, touch is an important sense,



often utilized by the CDD to engage the consumer with certain touchpoints (i.e. packaging, interactive exhibition, product).

In other words, emotional branding concentrates on decoding the consumer's emotional needs and desires to build a connection between the consumer and the brand, based on relationships and the use of human senses to emphasize particular characteristics of a product or service. Emotional branding is the connection between the consumer and service, or between the consumer and product (Gobé, 2009, p. xix).

### Guerrilla Advertising

The elevated costs of traditional advertising media (i.e. television, print, and radio) and the constant growth of new technologies have forced the advertising discipline (AD) to find innovative ways to engage the public in unfamiliar ways (Lucas 2006, p. 18). Besides, if the purpose of design is to grab people's attention, it has to be extraordinary and is more likely to happen with something new, that has not been seen before (Stoklossa, 2007, p. 6).

The AD is constantly searching for new possibilities to engage with the audience in places such as waiting rooms, bathrooms, parking lots, swimming pools, etc. (Pricken, 2008, p. 198). In brief, GA uses unexpected places to engage its audience in unexpected ways.

### Responsible Design

The purpose of the CDD is to communicate a specific message to a specific target and manifests itself in the form of persuasion, protest, information, and recreation (Twemlow, 2006, p. 46), but change in human consciousness and persuasion of human behavior is among the most difficult tasks in the CDD (Cranmer & Zappaterra, 2003,

p. 23). Additionally, it is easy for communication designers—especially those with less experience—to forget that clients usually are foreign to the CDD (i.e. doctors, lawyers, bankers, farmers, economists), consequently some clients do not understand the designer’s language (i.e. visual, esoteric) (Bierut, 2007, p. 17). In other words, today designers sometimes design for their peers and do not design for the final audience; there is emphasis on aesthetics and theories rather than meaning and purpose. Alice Twemlow (2006), a prolific design writer, design critic, and PhD candidate at the Royal College of Art affirms that “designers who want their work to inform, delight, [change human consciousness] and connect, will need to know much more about the people they are talking to, their beliefs, and backgrounds” (p. 80); an issue that could be easily resolved by observing their target situated in context, studying their cultures, their history, and “become well-rounded intellectually” as stated by Michael Bierut (2007, p. 17)—a graphic designer, design critic, educator, and partner at Pentagram, an international design firm—while explaining why the work of designers from the 1940s and ’50s continues to be interesting and not appear dated or irrelevant as more current work sometimes does (p. 17).

In the end—regardless of what the message is, who the target is, if the designer is intellectually equipped, or if the client is aware of the need—the choice to make a vital contribution solely relies on the communication designer (CD), and only two choices exist, to be passive or to be proactive (Glaser, 2006, p. 148). Additionally, Milton Glaser, who is among the most celebrated graphic designers in the United States, describes the challenge of moving people to action as two simple steps; “moving people or changing behavior...you can raise consciousness or most significantly, you could develop a sense

of empathy with others, who share a common experience” (Hong, 2010). Still, at the end it is a personal choice.

## **CHAPTER III**

### **OUTCOME RATIONALE**

#### **Brand Identity**

As described in its mission, one of IJM's objectives is to ensure justice for victims of slavery and sexual exploitation (mainly children) and to prosecute perpetrators. To effectively communicate this impact on the human being and to build personal relationships with the victims easily, human shapes are used as an integral part of the proposed IJM mark. Since the color black is associated with positive connotations (i.e. power, strong, prestigious, and modern) as well as negative (i.e. death, evil, and oppression) (Eiseman, 2006, p. 65); the subtle, almost invisible, contrast between a matte black against a glossy black, represents the hidden but existent social problems IJM confronts. Once they are noticed, they cannot be ignored.

#### **Traveling Exhibition**

The individual's demand for a new brand experience has led brands to expand the brand interactivity beyond the traditional brand touchpoints (i.e. advertising, corporate communications, marketing materials). Just as important as the product, service, or the brand itself, is the branded space (i.e. exhibition, restaurant, office, store) and brand experience (Berger, et al. 2007, p. 22). Because the ultimate goal of an exhibition is to engage with the visitor while providing relevant information (Hughes, 2010, p. 34)

the storyline and visitor interactivity have a direct influence on how the exhibition is perceived by the visitor. Consequently, if the visitor takes an important role, the exhibition has more impact than a one-way communication channel. Hence, the visitors play the most important role, which is to build the Bricks for Justice wall (BJW).

Bricks are placed at the exhibition entrance; strategically placed above this pile of bricks are instructions (see Figure 1). Visitors are encouraged to pick up a brick at the exhibition entrance to carry through the space, to then sign and to place on the growing wall. As the BJW gets taller, it will cover a list of social problems written on the wall behind it (see Figure 2).



*Figure 1.* Bricks at Entrance of the Exhibition.

Metaphorically, the BJW represents the victory against the social problems IJM confronts. The order of the information presented to the visitor is as important as the information itself; since the brain is more alert at the beginning and the end of a new situation, is important to create a powerful impression at the beginning and at the end with a powerful grabber (Renvoisé & Morin, 2007. p. 70). The BJW exhibition has two

powerful grabbers; first, asking the visitor to take and carry a brick before entering the exhibition and secondly, the on-going construction of the BJW covering the social problems IJM confronts. In addition to represent a symbolic pledge, the action of carrying bricks evokes empathy with the slaves carrying bricks all day at brick kilns.

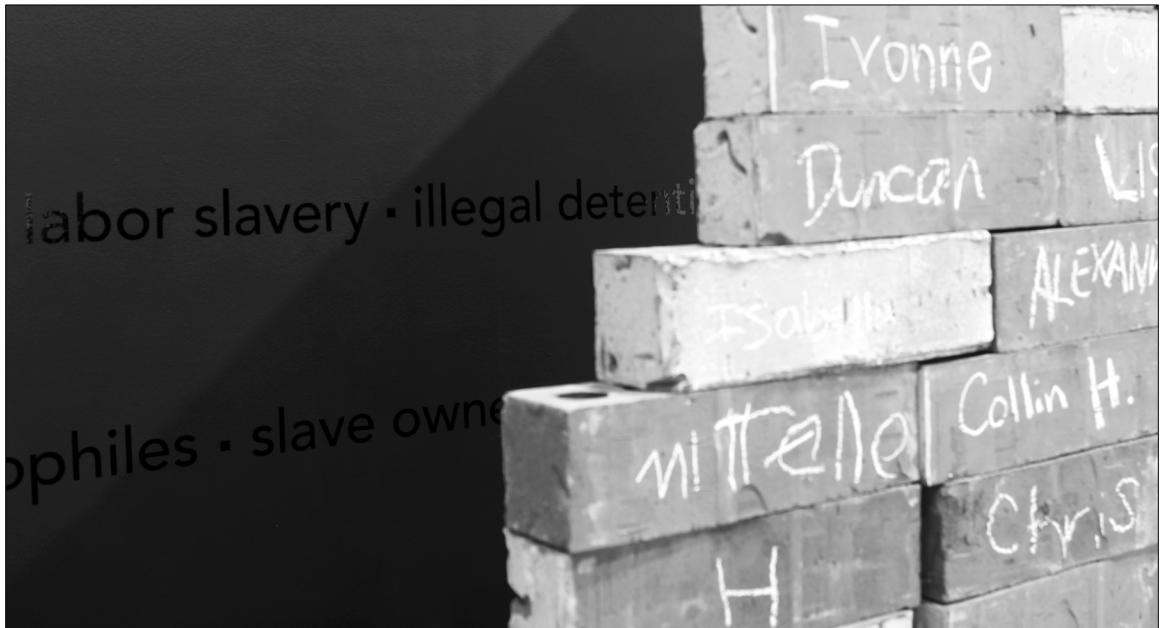

*Figure 2.* The BJW Covering a List of Social Problems.

As the visitors enter the exhibit, they are immediately confronted with a floor covered in children's clothes, representing the missing children who have been trafficked by perpetrators. Visitors are forced to step on the clothes to reach the BJW before exiting (see Figure 3). The forced interaction of stepping on the clothes metaphorically represents the victims' dignity being stepped on.

The prevalent use of black and white shapes was chosen to express extreme opposites, and symbolically represent good vs. evil (Eiseman, 2006, p. 64). Additionally, to effectively prevent any nationality or gender bias, solid white and black shapes are used in the exhibition to present the stories of former victims stories, as well as to present the facts and statistics. However, black and white photography—in the form of

portraits—is used at the end of the exhibition to illustrate success stories of former victims rescued by IJM (see Figure 4).



*Figure 3. Children's Clothing.*

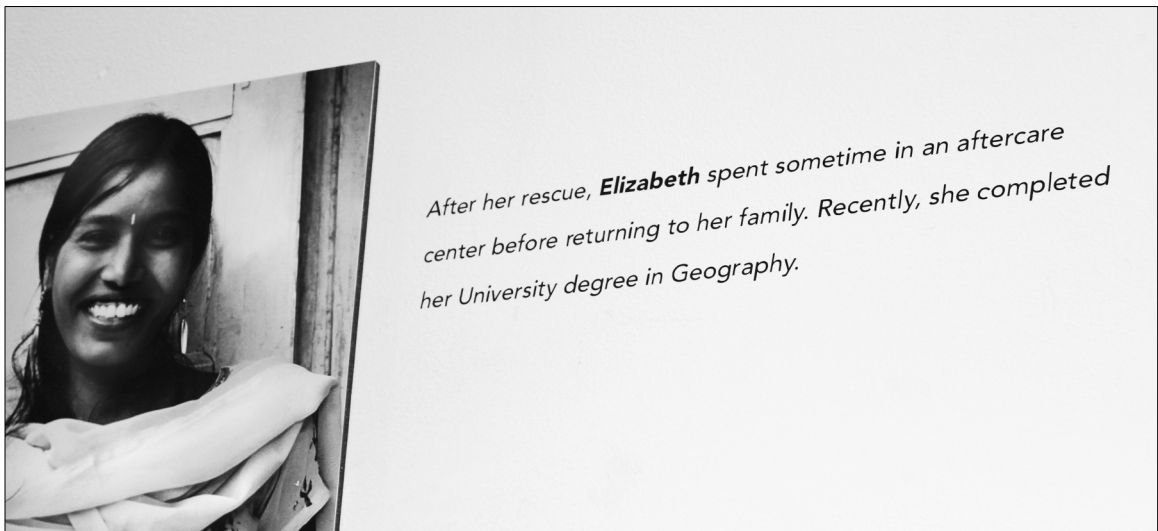

*Figure 4. Portrait of a Former Victim.*

### Guerrilla Advertising Installations

The GA installations consist of an adult male silhouette applied to each mirror in the women's restroom and a female child silhouette applied to each mirror in the men's restroom (see Figure 5 and Figure 6).



Figure 5. GA Installation in Women's Restroom.



Figure 6. GA Installation in Men's Restroom.



The objective of using provocation and shock tactics in advertising is to stimulate the viewer's emotions (Pricken, 2008, p. 80); in this case, because the installations were in the restroom, the viewer's privacy was invaded thereby provoking emotions such as fear, anger, or affliction.

## **CHAPTER IV**

### **CONCLUSION**

This thesis, Bricks for Justice, a Traveling Exhibition for International Justice Mission, a Human Rights Organization, documents how the CDD may have a positive impact in society by provoking a change in human consciousness in the visitor; first by using space to engage, to provide relevant information, and to interact with the visitor (i.e. exhibition). Secondly, by depicting the human aspect of IJM's objectives in their identity rather than a governmental resemblance and showcasing the hidden but existent social problems IJM confronts, which, once they are noticed, cannot be ignored. Finally, the CDD may have a positive impact by using GA installations to engage the visitor in unexpected ways in unexpected places, creating a lasting impression in the visitors of the risks and facts about sex crimes, an issue interrelated with sex trafficking, one of several social problems IJM confronts in 13 different countries.

Bricks for Justice was exhibited at the Art Gallery of Texas State University-San Marcos in March 2012. During this process, visitor behavior was closely observed, providing information for possible design improvements and future research possibilities.

When visitors entered the exhibit space, they expressed discomfort and were worried where to step, always trying to step away from the children's clothing. However, when the flow got congested, it was observed that some visitors stepped over the children's clothes. The use of short and concise facts helped to keep the flow of people

moving relatively fast.

The visitor's interaction with the BJW was successful. During the second day of the exhibition being open, most of the bricks were already placed and signed on the wall (see Figure 8). In fact, the BJW had to be rearranged to allow more visitors to participate by signing and placing more bricks on the wall, at the end of the exhibit, 87.5% of the bricks were signed. That is 154 out of the 176 bricks available for signing.



Figure 8. The BJW.

### Future Creative Investigations

Through the design process and observation of the visitor's interaction with the BJW during the exhibition opening, additional ideas for possible research projects evolved. The ideas for possible future investigations are:

1.) Can digital interaction (i.e. smartphone or tablet applications) enhance the visitor experience? If yes, how could this be possible? Can augmented reality be part of the digital interaction? How would this enhance the visitor experience?

2.) Can staff in disguises or staff characterization provoke a more shocking impact on the viewers? Would this benefit or provide an advantage to better engage with the viewer?

3.) Can sound be incorporated in the exhibition? How would this affect or benefit the visitor experience?

4.) Can the exhibition be displayed in open spaces? What would be the benefits or disadvantages?

5.) Can the exhibition be done online? Would it have the same impact?

6.) What would be the benefits or disadvantages of using different materials?

7.) Can the exhibition be pre-assembled? What would be the benefits or disadvantages?

8.) Can the idea of the travelling exhibition be used for other clients?

9.) The BJW has great symbolic value and it raises awareness among the viewers. However, to provoke a direct action from the viewers (i.e. to make donations, to become volunteers, or to receive further IJM information) access to printed or digital material (i.e. sign-up forms, brochures, IJM staff and victims' testimonials) must be provided during the exhibition to the viewers wanting to pursue further action.

What would be the benefits or disadvantages of presenting the forms before or after the BJW? What would be the benefits or disadvantages of using digital vs. printed materials?

**APPENDIX A**

IDENTITY OUTCOME

EGD OUTCOME

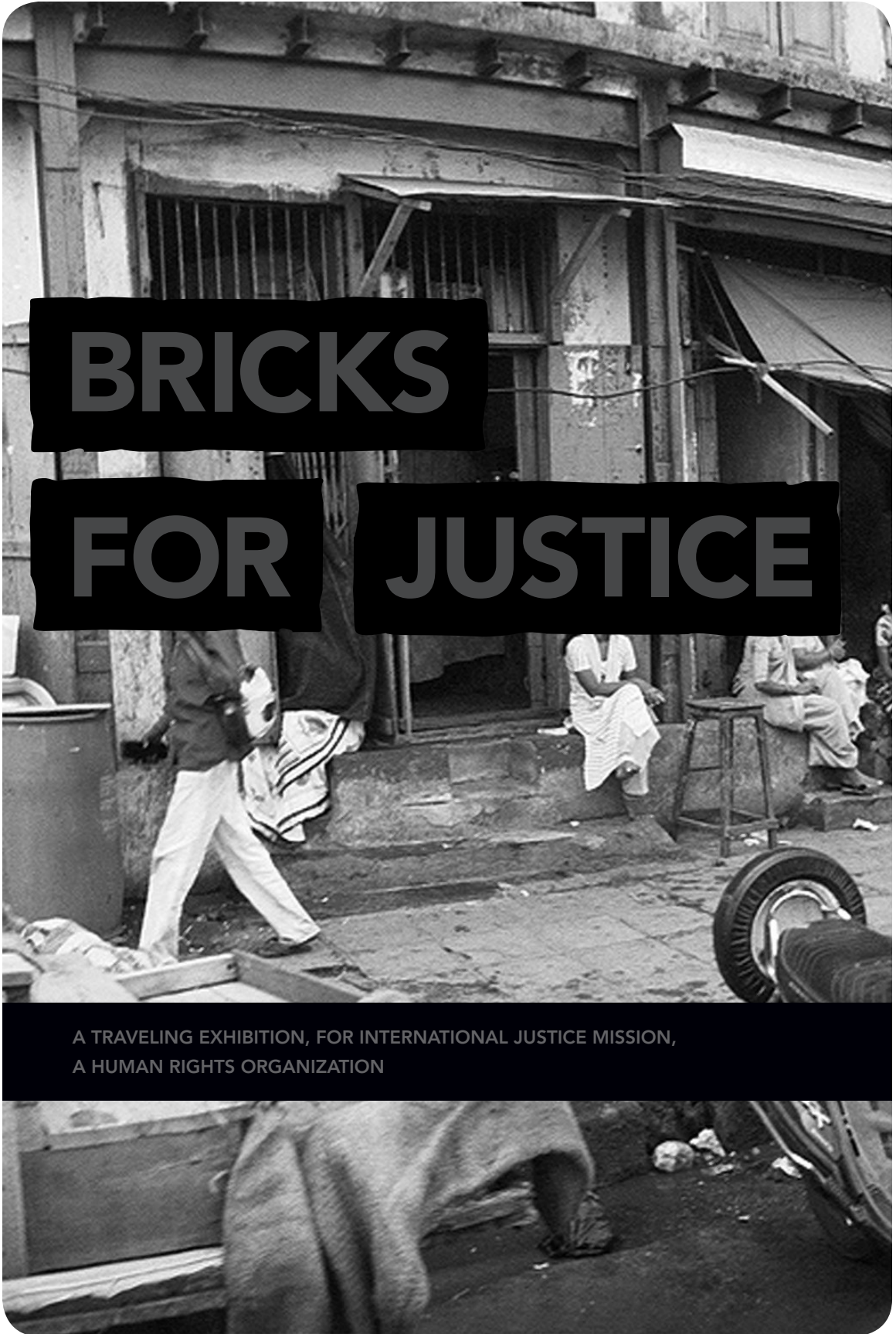

A TRAVELING EXHIBITION, FOR INTERNATIONAL JUSTICE MISSION,  
A HUMAN RIGHTS ORGANIZATION

"Learn to do good. Seek justice. Help the oppressed.  
Defend the cause of orphans. Fight for the rights of widows."  
(Isaiah 1:17, New Living Translation)



"[Branding] above all makes the strategy of the organization visible and palpable for all audience to see."

(Olins, 2008, p. 21)



**ID CREATIVE PROCESS**



---

**IDENTITY OUTCOME**

IJM's objectives is to ensure justice for victims of slavery and sexual exploitation (mainly children) and to prosecute perpetrators. To effectively communicate this impact on the human being and to build personal relationships with the victims easily, human shapes are used as an integral part of the proposed IJM mark. At the same time this graphic solution eliminates the reproduction constraints and the government resemblance of the existent IJM's emblem.

Basic identity applications and a typographic palette are presented to showcase the proposed IJM identity. Applications include: stationery system (i.e. letterhead, envelope, and business cards), ephemera (i.e. caps, t-shirts, toys), and digital (i.e. smart-phone application icon and web site).

---

**IDENTITY OUTCOME**

Proposed Brandmark



**IDENTITY OUTCOME**

Brandmark Morphological Approach

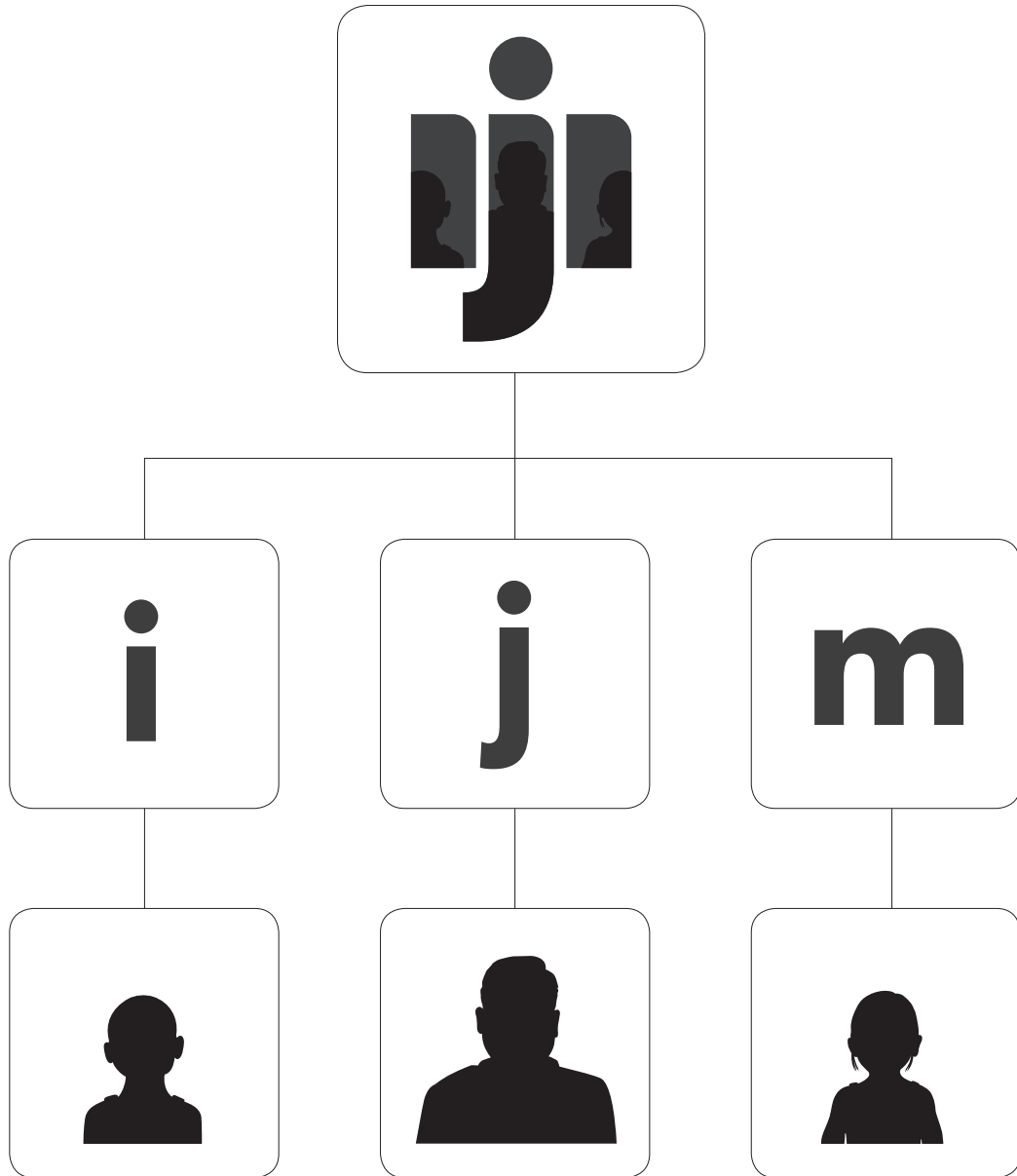

---

**IDENTITY OUTCOME**

Proposed Signature





**IDENTITY OUTCOME**

Identities Comparison



Existent identity



Proposed identity

ABCDEFGHIJKLMNOPQRSTUVWXYZ  
abcdefghijklmnopqrstuvwxyz 1234567890&?!  
*Avenir Light*

ABCDEFGHIJKLMNOPQRSTUVWXYZ  
abcdefghijklmnopqrstuvwxyz 1234567890&?!  
*Avenir Roman*

*ABCDEFGHIJKLMNOPQRSTUVWXYZ*  
*abcdefghijklmnopqrstuvwxyz 1234567890&?!*  
*Avenir Oblique*

ABCDEFGHIJKLMNOPQRSTUVWXYZ  
abcdefghijklmnopqrstuvwxyz 1234567890&?!  
*Avenir Medium*

**ABCDEFGHIJKLMNOPQRSTUVWXYZ**  
**abcdefghijklmnopqrstuvwxyz 1234567890&?!**  
*Avenir Heavy*

**ABCDEFGHIJKLMNOPQRSTUVWXYZ**  
**abcdefghijklmnopqrstuvwxyz 1234567890&?!**  
**Avenir Black**



1235 S Clark Ste 1400 p 703.465.5495  
Arlington, VA 22202 f 703.465.5499

March 30, 2012

Gary Haugen  
President  
International Justice Mission  
7007 Winchester Circle Ste 140  
Boulder Colorado, 80301

Dear Mr. Haugen,

Duis feugiat vehicula enim, nec hendrerit ante placerat auctor. Praesent tristique ligula et ligula volute pat hendrerit. Aliquam egestas, eros et venenatis ornare, nibh nisl lacinia libero, nec elementum nulla lorem sed velit. Duis fermentum pulvinar ipsum non placerat. Praesent vel porta nisl. Nam massa dolor, imperdiet nec suscipit consectetur, placerat et quam.

Duis feugiat vehicula enim, nec hendrerit ante placerat auctor. Praesent tristique ligula et ligula volutpat hendrerit. Aliquam egestas, eros et venenatis ornare, nibh nisl lacinia libero, nec elementum nulla lorem sed velit. Duis fermentum pulvinar ipsum non placerat. Praesent vel porta nisl. Nam massa dolor, imperdiet nec suscipit consectetur, placerat et quam.

Duis feugiat vehicula enim, nec hendrerit ante placerat auctor. Praesent tristique ligula et ligula volutpat hendrerit. Aliquam egestas, eros et venenatis ornare, nibh nisl lacinia libero, nec elementum nulla lorem sed velit. Duis fermentum pulvinar ipsum non placerat. Praesent vel porta nisl. Nam massa dolor, imperdiet nec suscipit consectetur, placerat et quam.

Lent tristique ligula et ligula volutpat hendrerit. Aliquam egestas, eros et venenatis ornare, nibh nisl lacinia libero, nec elementum nulla lorem sed velit. Duis fermentum pulvinar ipsum non placerat. Praesent vel porta nisl. Nam massa dolor, imperdiet nec suscipit consectetur, placerat et quam.

Respectfully yours,



Genaro S. Rivero  
Graphic Designer



**IDENTITY OUTCOME**

STATIONARY SYSTEM | BUSINESS CARDS AND ENVELOPE

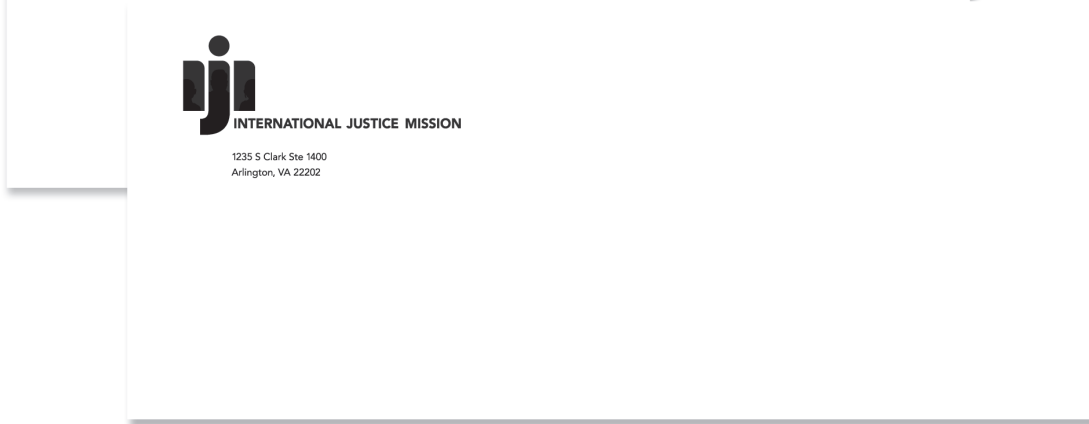

IDENTITY OUTCOME

EPHEMERA



IDENTITY OUTCOME

DIGITAL



IDENTITY OUTCOME  
DIGITAL (CONTINUED)

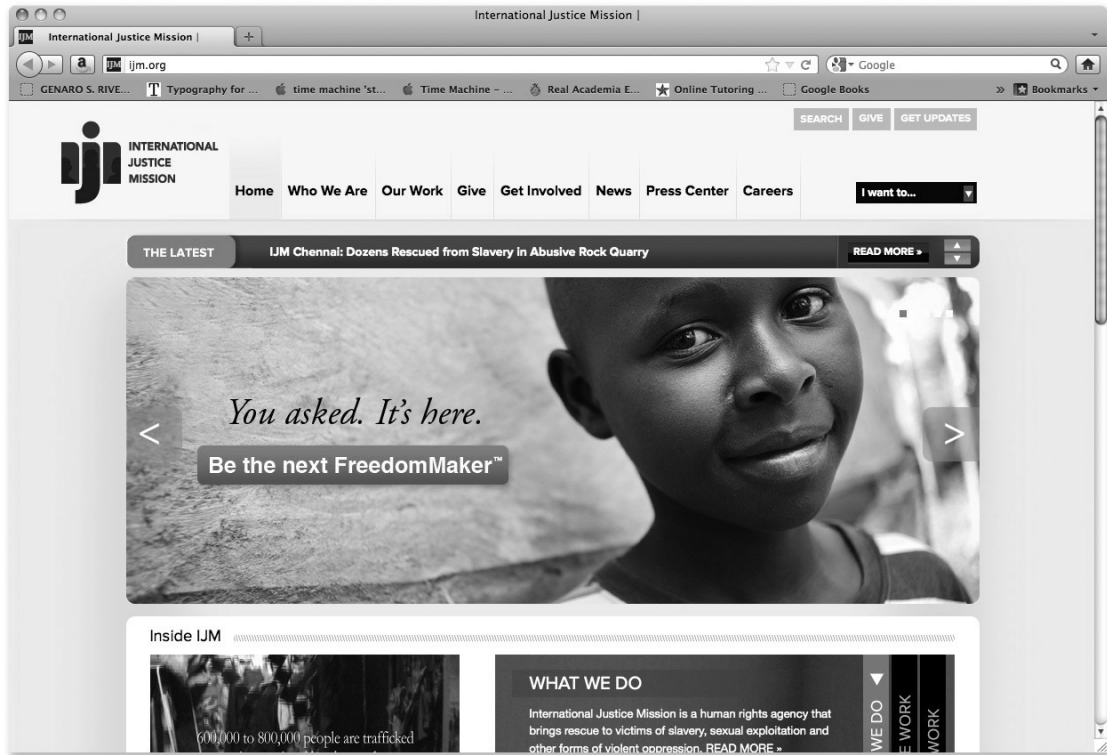

"The impact of an exhibition increases as the visitor becomes more active and invested."

(de Jong & Kossmann, 2010, p. 78)

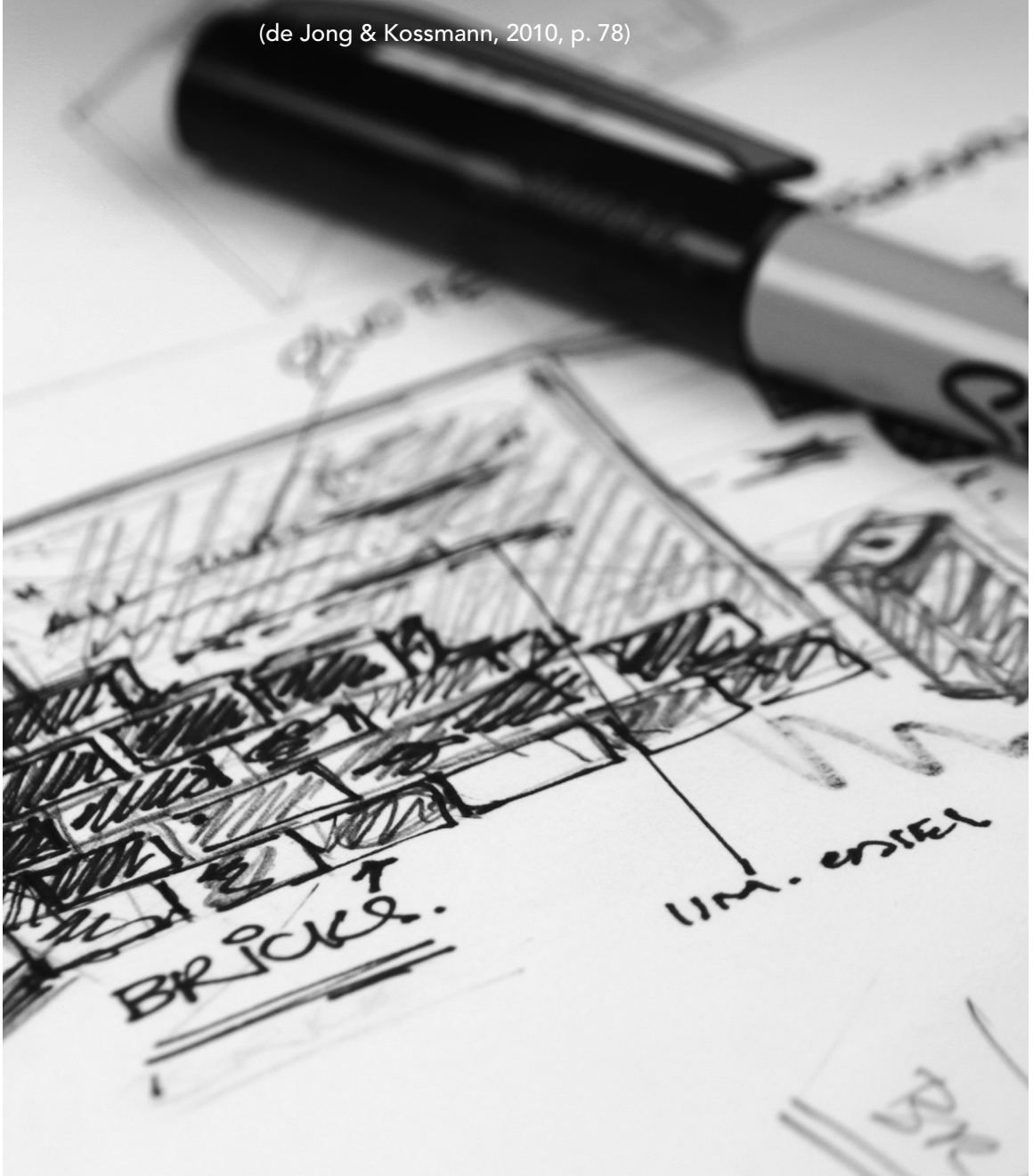

**EGD CREATIVE PROCESS**

---

**EGD OUTCOME**

The graphic elements proposed for this traveling exhibition are aligned to the proposed IJM's identity style to maintain a coherent brand message and to reinforce brand recognition. Also, the use of graphic forms prevents the viewer having any gender or ethnicity bias.

The following schematics present the suggested storyline, the wall layouts, and the proposed materials and specifications for each individual graphic component of the traveling exhibition.

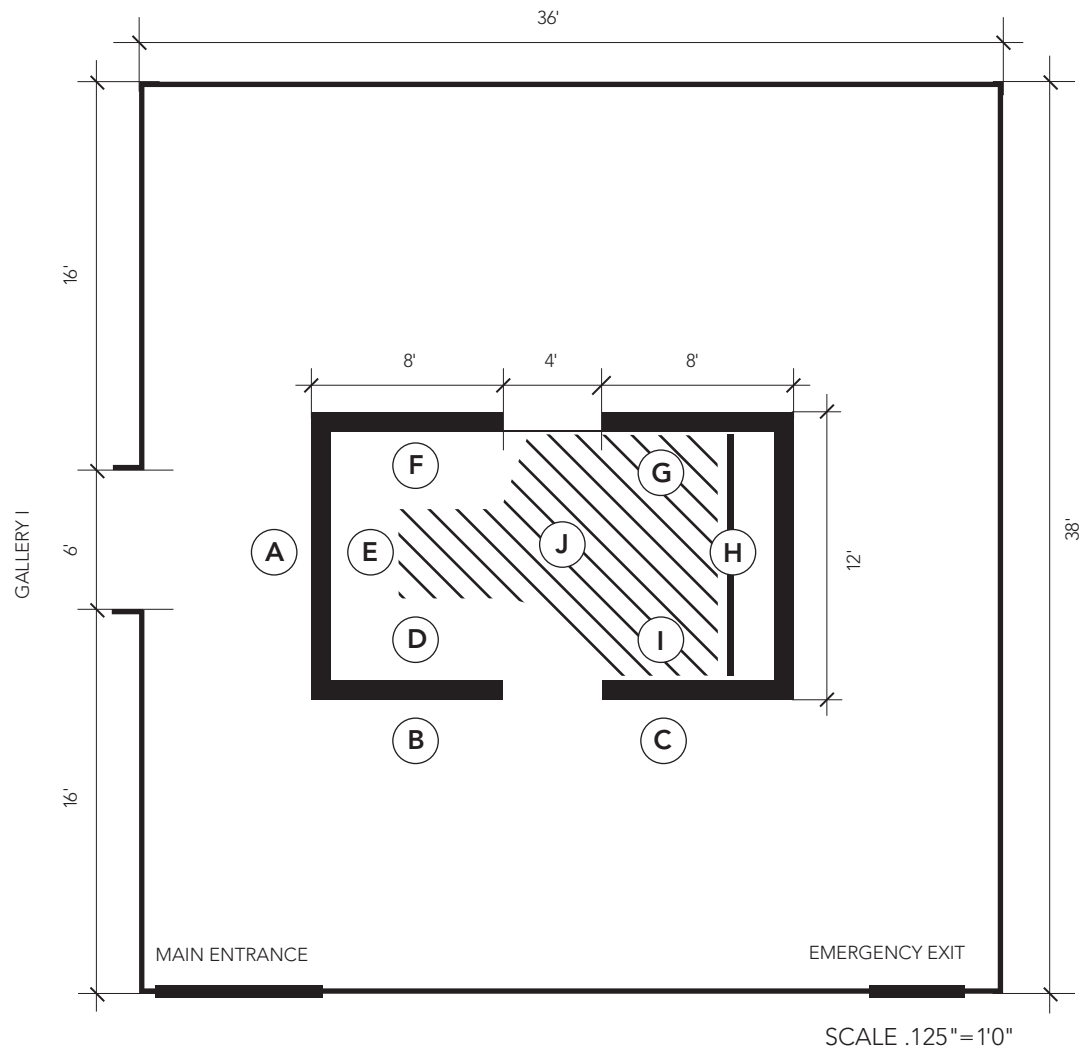

- |                                |                                      |
|--------------------------------|--------------------------------------|
| <b>A</b> BIBLE VERSE           | <b>F</b> STATISTICS 2                |
| <b>B</b> IJM MISSION STATEMENT | <b>G</b> JULIANNA'S STORY            |
| <b>C</b> EXHIBITION TITLE      | <b>H</b> THE BRICKS FOR JUSTICE WALL |
| <b>D</b> STORIES               | <b>I</b> FORMER VICTIMS              |
| <b>E</b> STATISTICS 1          | <b>J</b> CHILDREN'S CLOTHING         |

*"When evil people come to devour me, when my enemies and  
foes attack me, they will stumble and fall."  
—Psalm 27:2, NLT*



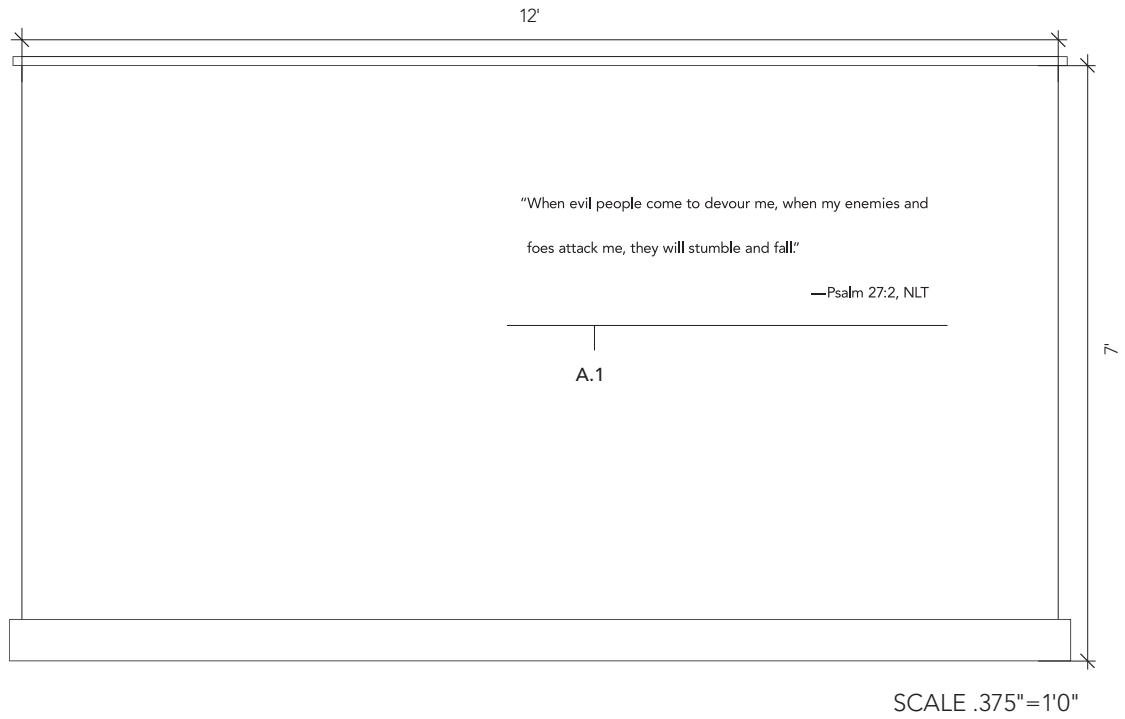

**A.1 Bible verse.**

“When evil people come to devour me, when my enemies and  
foes attack me, they will stumble and fall.”

—Psalm 27:2, NLT

(Psalm 27:2, New Living Translation)

**A.1 Bible verse.** Standard black matte vinyl, applied directly to painted white wall. Text set FL, Avenir Roman, 140/420 pt



## INTERNATIONAL JUSTICE MISSION

IJM is a human rights agency that secures justice for victims of slavery, sexual exploitation and other forms of violent oppression. IJM lawyers, investigators and aftercare professionals work with local officials to ensure immediate victim rescue and aftercare, to prosecute perpetrators and to promote functioning public justice systems.

**B** IJM MISSION STATEMENT

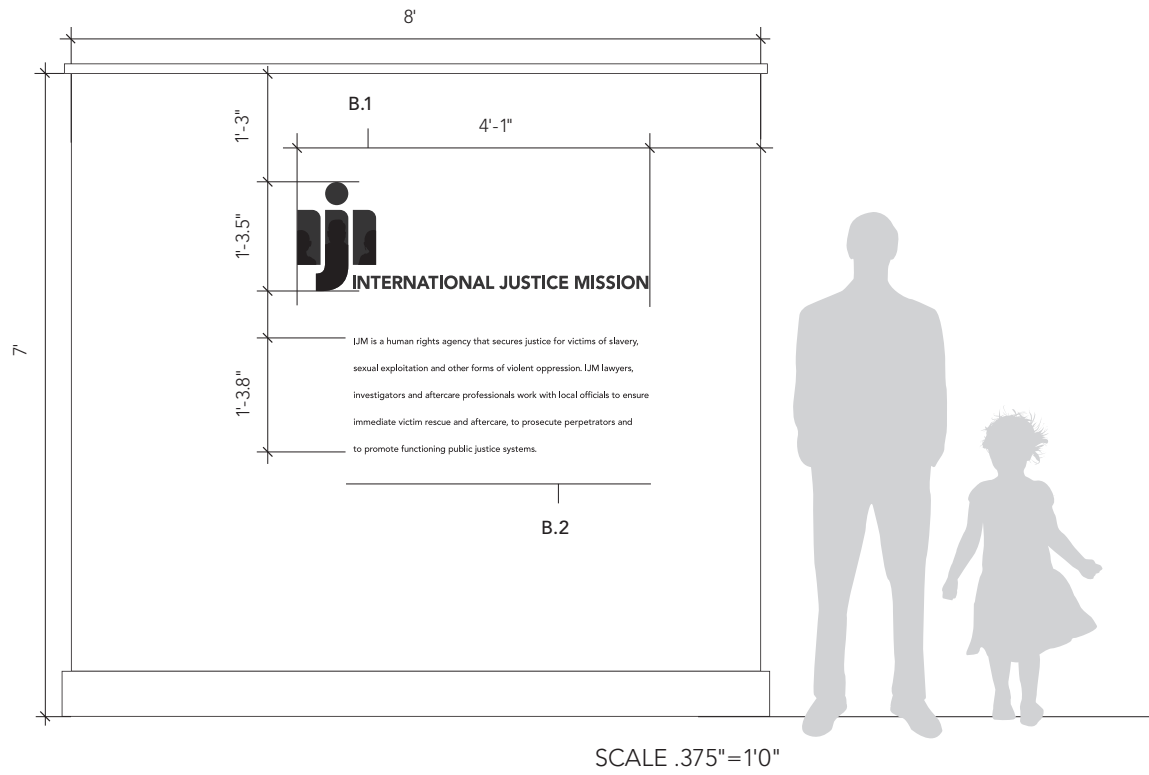

**B.1 IJM signature.**

**B.2 IJM mission.**



- B.1 IJM signature.** Standard black matte vinyl, applied directly to painted white wall. Human silhouettes. Standard black glossy vinyl, applied directly to matte vinyl.

IJM is a human rights agency that secures justice for victims of slavery, sexual exploitation and other forms of violent oppression. IJM lawyers, investigators and aftercare professionals work with local officials to ensure immediate victim rescue and aftercare, to prosecute perpetrators and to promote functioning public justice systems.

(IJM, 2011).

- B.2 IJM mission.** Standard black matte vinyl, applied directly to painted white wall. Text set FL, Avenir Medium, 90/270 pt



# BRICKS FOR JUSTICE

A TRAVELING EXHIBITION  
FOR INTERNATIONAL JUSTICE MISSION  
A HUMAN RIGHTS ORGANIZATION

BEFORE ENTERING THE EXHIBIT  
PLEASE TAKE A BRICK WITH YOU

children are  
al commerc  
e

C EXHIBITION TITLE

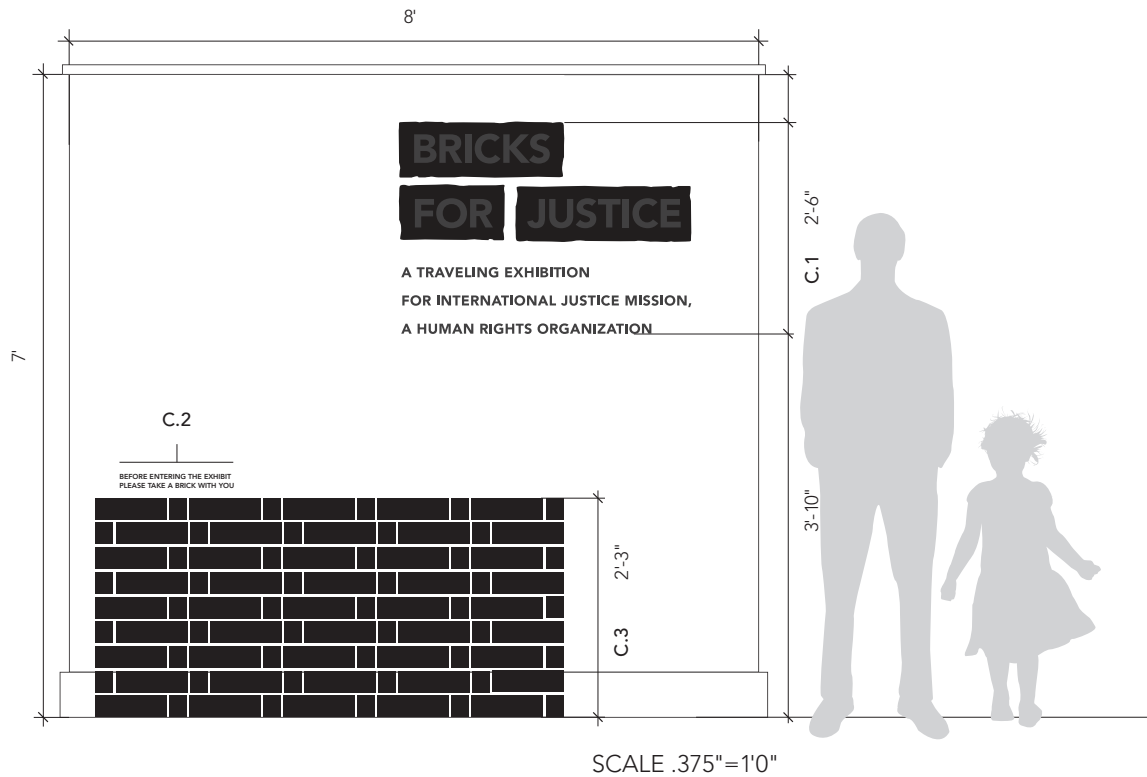

**C.1 Exhibition title.** Standard black matte vinyl, applied directly to bricks shapes. Text set FL, all caps, Avenir Black.

Bricks shapes. Standard black glossy vinyl, applied directly to painted white wall.

Subtitle. Standard black matte vinyl, applied directly to painted white wall. Text set FL, all caps, Avenir Black, 144/288 pt

**C.2 Entrance instructions.** (Before entering the exhibit, please take a brick with you) Standard black matte vinyl, applied directly to painted white wall. Text set FL, all caps, in Avenir Light, 56/72 pt

**C.3 Clay bricks.** Model Binzo Old Cade, 10"×2.75"×3", individual weight approximately 3.5 lbs



D STORIES



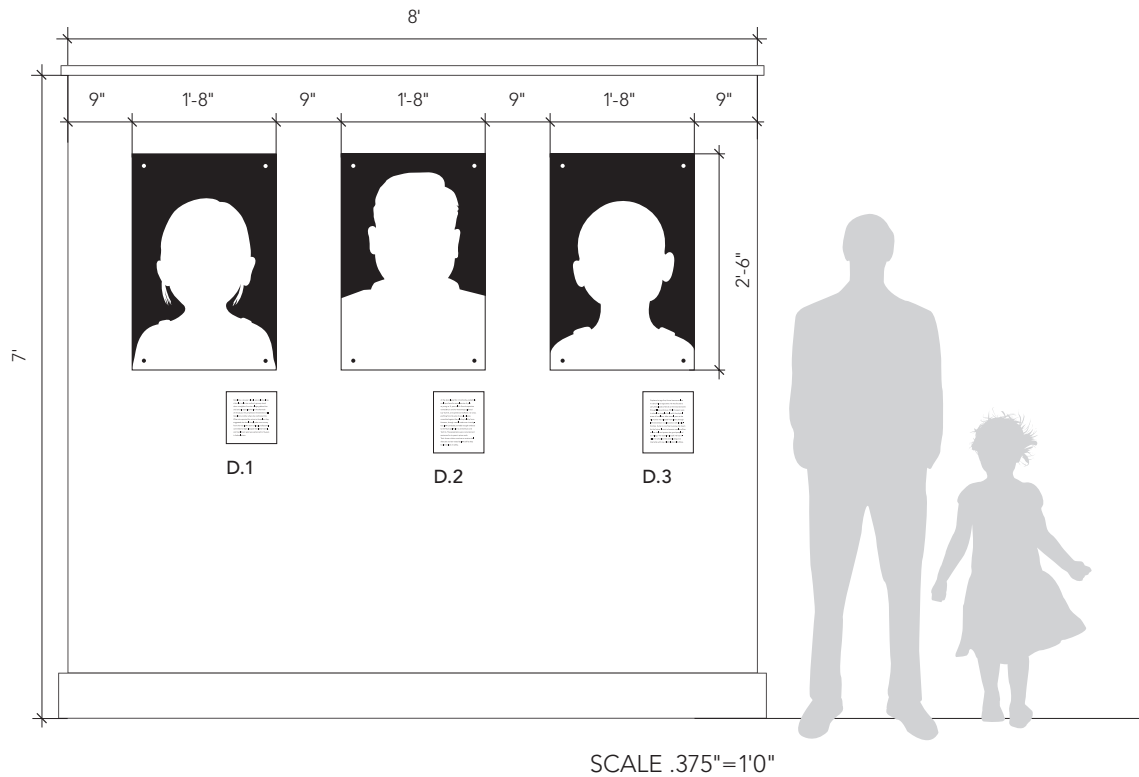

**Silhouettes.** Standard black matte vinyl, mounted flush on 3 mm 20"×30" white Komatex® panels, mounted to painted white wall, supported by aluminum stand-offs.

**D.1 Sex trafficking victim portrait.**

**D.2 Perpetrator portrait.**

**D.3 Brick kiln slave portrait.**

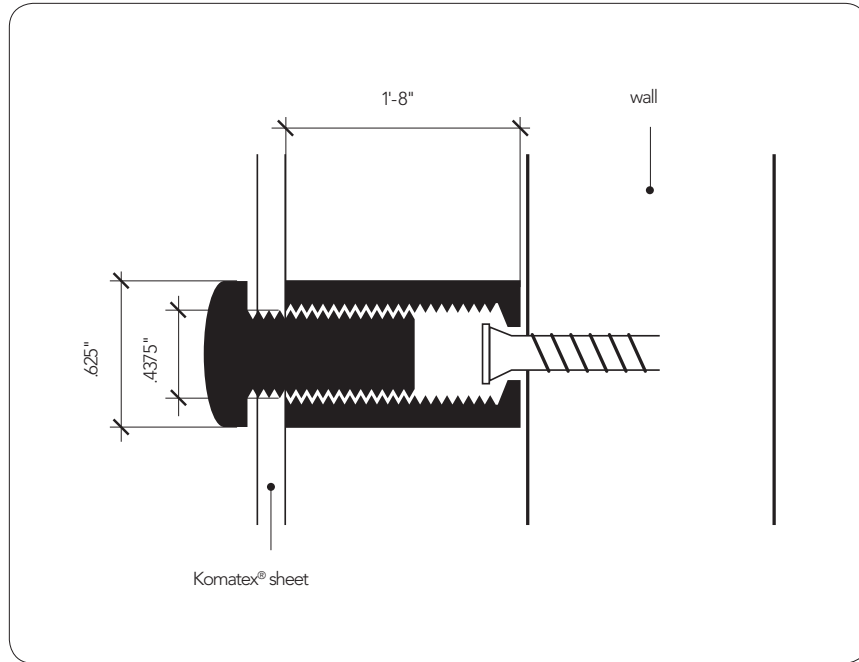

Aluminum Stand-offs.

Geraldine, a six year old girl, was walking along a familiar trail to her mother's grocery stand when a neighbor from her village grabbed her and sexually assaulted her. In the aftermath of the abuse, the perpetrator threatened to kill Geraldine's mother when she confronted him. When she reported the crime to the police, they suggested she should simply take some money from the man. IJM's team of legal professionals committed to fight alongside Geraldine's family, and Geraldine's rapist was sentenced to 12 years in federal prison.

(IJM, 2010c).

**D.1 Former sex trafficking victim story.**

Avery® Clear Inkjet Labels, applied directly to painted white wall. Text set FL, Avenir Roman, 16/32 pt

At the Apocalypse Bar in Cambodia, pedophiles could purchase the sexual service of girls as young as 11 years old. A French expatriate named Bruno and his Vietnamese girlfriend Ley Tach Va, an experienced trafficker, ran a bar, profiting from the acts of sexual violence committed against the girls they held by force. However, through careful undercover investigation, IJM Cambodia provided enough evidence to the Municipal Police to arrest Bruno and Tach Va. The perpetrators were convicted and sentenced to six years in prison each. Their former victims continue to receive vital aftercare and are visited by IJM staff as they build new lives in safety.

(IJM, 2007).

#### **D.2 Former perpetrator story.**

Avery® Clear Inkjet Labels, applied directly to painted white wall. Text set FL, Avenir Roman, 16/32 pt

Orphaned at age five, Kumar became a slave in a brick kiln at age seven. He was forced to carry heavy loads of bricks on his head and work through illness and injury. While his peers were in school, he struggled daily with the physical stress of hard labor. After several years at the kiln, Kumar was released from slavery through IJM intervention in collaboration with local authorities. Kumar is now free to pursue his dream for the future: "I want to become a police officer so I can help and protect the good people of our village," he recently told staff. He has excelled in school and has recently begun an internship with one of IJM's India field offices.

(IJM, 2008).

### **D.3 Former brick kiln slave story.**

Avery® Clear Inkjet Labels, applied directly to painted white wall. Text set FL, Avenir Roman, 16/32 pt

**E** STATISTICS

**\$32**  
**billion** total yearly profits,  
in U.S. dollars,  
generated by the human  
trafficking industry



**2 million children** are exploited  
by the global commercial sex trade;  
between 200,000 and 300,000  
are prostituted in the United States





- E.1 Children.** Standard black matte vinyl, applied directly to painted white wall. Life size, approximately 3'-10"
- E.2 2 million children statistic.**
- E.3 32 billion statistic.**

**2 million children** are exploited  
by the global commercial sex trade;  
between 200,000 and 300,000  
are prostituted in the United States

(Bales, 2004).

- E.2 2 million children statistic.** Standard black matte vinyl,  
applied directly to painted white wall.  
Text set FL, Avenir Roman, Avenir Bold, 4.64"/6.5"

**\$32  
billion** total yearly profits,  
in U.S. dollars,  
generated by the human  
trafficking industry

(Beate, 2008, p. 7).

- E.3 32 billion statistic.** Standard black matte vinyl,  
applied directly to painted white wall.  
Main text set FL, Avenir Roman, 99/199 pt,  
highlight set C, Avenir Black, 6.5" and 3.9"



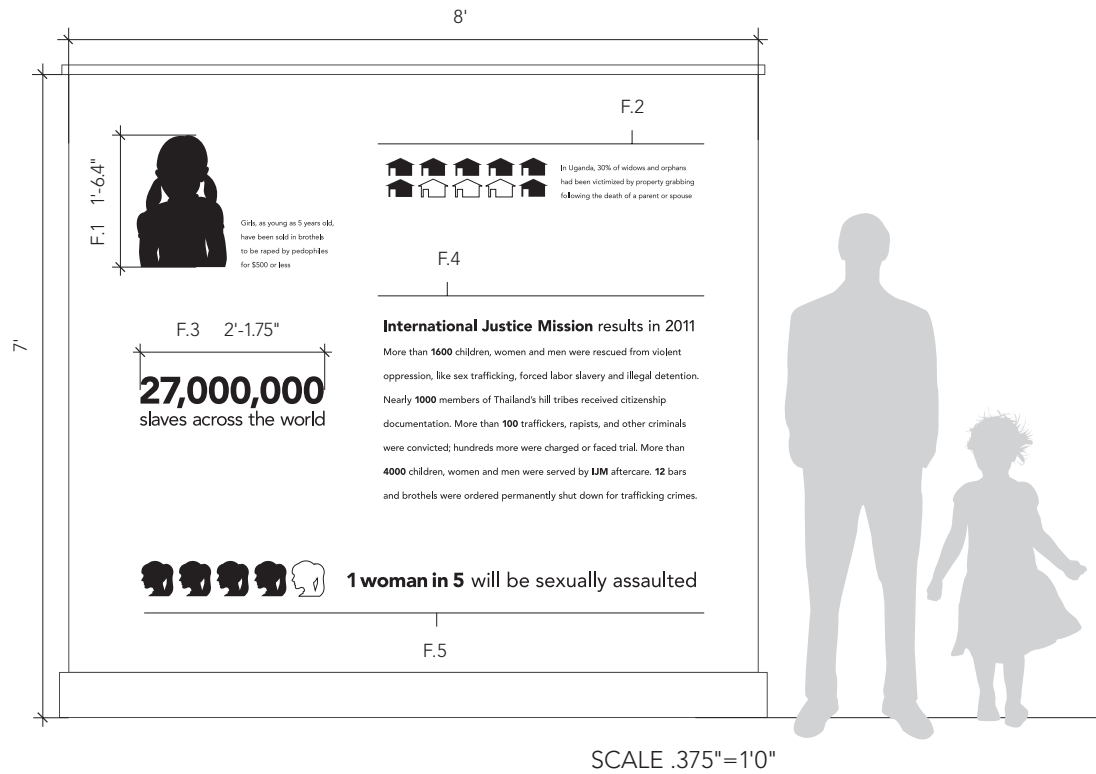

F.1 Girl.

F.2 Uganda houses.

F.3 27,000,000 slaves.

F.4 IJM results in 2011.

F.5 1 woman in 5.

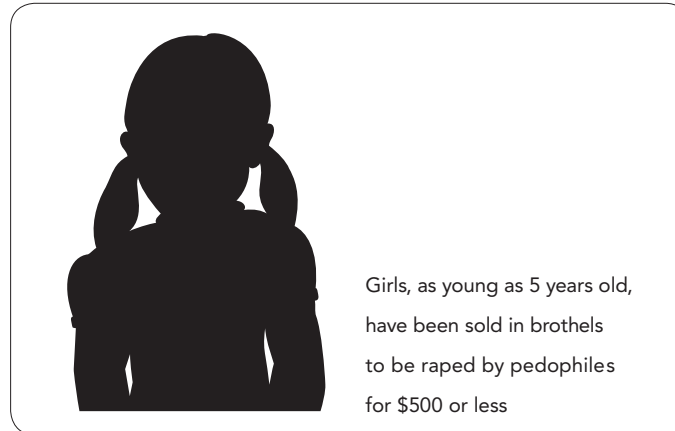

(IJM, 2011).

- F.1 Girl.** Shape and statistic are standard black matte vinyl applied directly to painted white wall.  
Text set in Avenir Roman, 72/140 pt



(IJM, 2011).

- F.2 Uganda houses.** Shapes and statistic are standard black matte vinyl applied directly to painted white wall.  
Text set in Avenir Roman, 72/140 pt

**27,000,000**  
slaves across the world

(Bales, 2004).

- F.3 27,000,000 slaves.** Statistic is standard black matte vinyl applied directly to painted white wall.  
Text set in Avenir Bold, 380 pt and Avenir Roman, 195 pt

## International Justice Mission results in 2011

More than **1600** children, women and men were rescued from violent oppression, like sex trafficking, forced labor slavery and illegal detention.

Nearly **1000** members of Thailand's hill tribes received citizenship documentation. More than **100** traffickers, rapists, and other criminals were convicted; hundreds more were charged or faced trial. More than **4000** children, women and men were served by **IJM** aftercare. **12** bars and brothels were ordered permanently shut down for trafficking crimes.

(IJM, 2012a).

**F.4 IJM results in 2011.** Results are standard black matte vinyl applied directly to painted white wall.

Text set in Avenir Bold, 157 pt, Avenir Roman and Avenir Bold, 95/240 pt



**1 woman in 5** will be sexually assaulted

(UNDPI, 2009).

**F.5 1 woman in 5.** Results are standard black matte vinyl applied directly to painted white wall.

Text set in Avenir Bold and Avenir Roman, 203 pt



G JULIANNA'S STORY

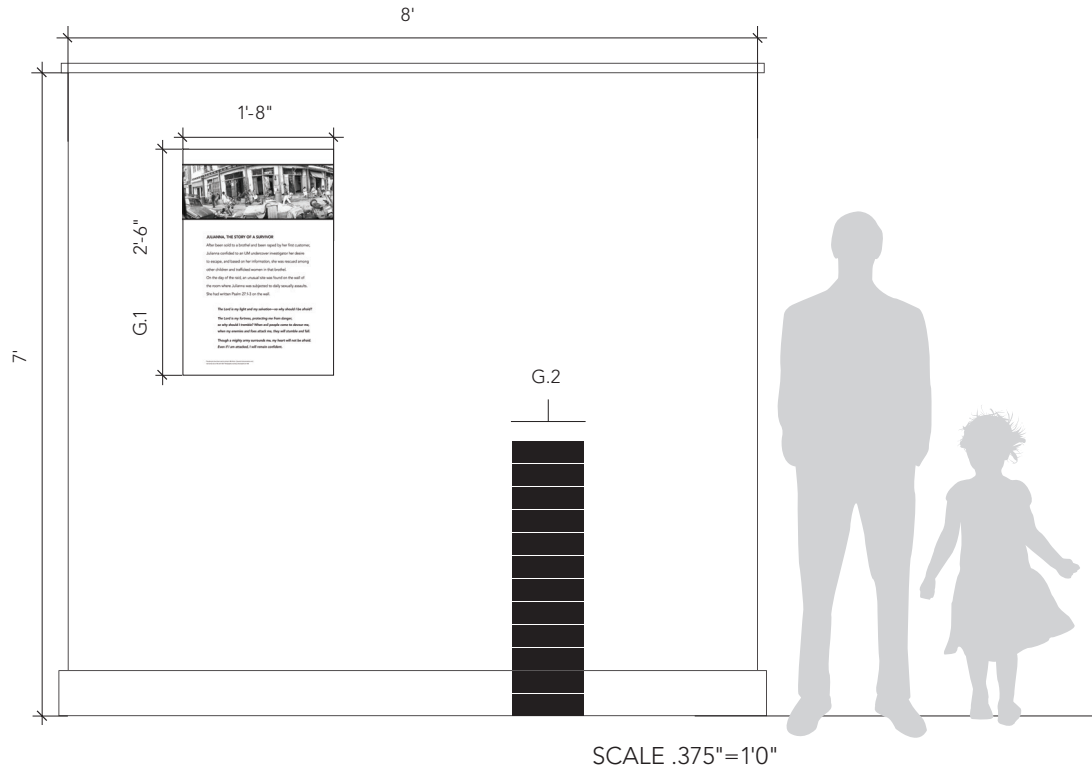

**G.1 Julianna, the story of a survivor.**

**G.2 Bricks for Justice wall.**



#### JULIANNA, THE STORY OF A SURVIVOR

After been sold to a brothel and been raped by her first customer, Julianna confided to an IJM undercover investigator her desire to escape, and based on her information, she was rescued among other children and trafficked women in that brothel.

On the day of the raid, an unusual site was found on the wall of the room where Julianna was subjected to daily sexually assaults. She had written Psalm 27:1-3 on the wall.

*The Lord is my light and my salvation—so why should I be afraid?*

*The Lord is my fortress, protecting me from danger,  
so why should I tremble? When evil people come to devour me,  
when my enemies and foes attack me, they will stumble and fall.*

*Though a mighty army surrounds me, my heart will not be afraid.  
Even if I am attacked, I will remain confident.*

Pseudonyms have been used to protect IJM clients. Casework documentation and real names are on file with IJM. Photography courtesy and property of IJM.

(IJM, 2006a).

**G.1 Julianna, the story of a survivor.** Photographic ink-jet print, mounted flush on 5 mm 20" × 30" black Fome-Cor® board, against painted white wall. Text set FL, Avenir Roman, 48/102 pt and Avenir Black, 42/80 pt

H THE BRICKS FOR JUSTICE WALL

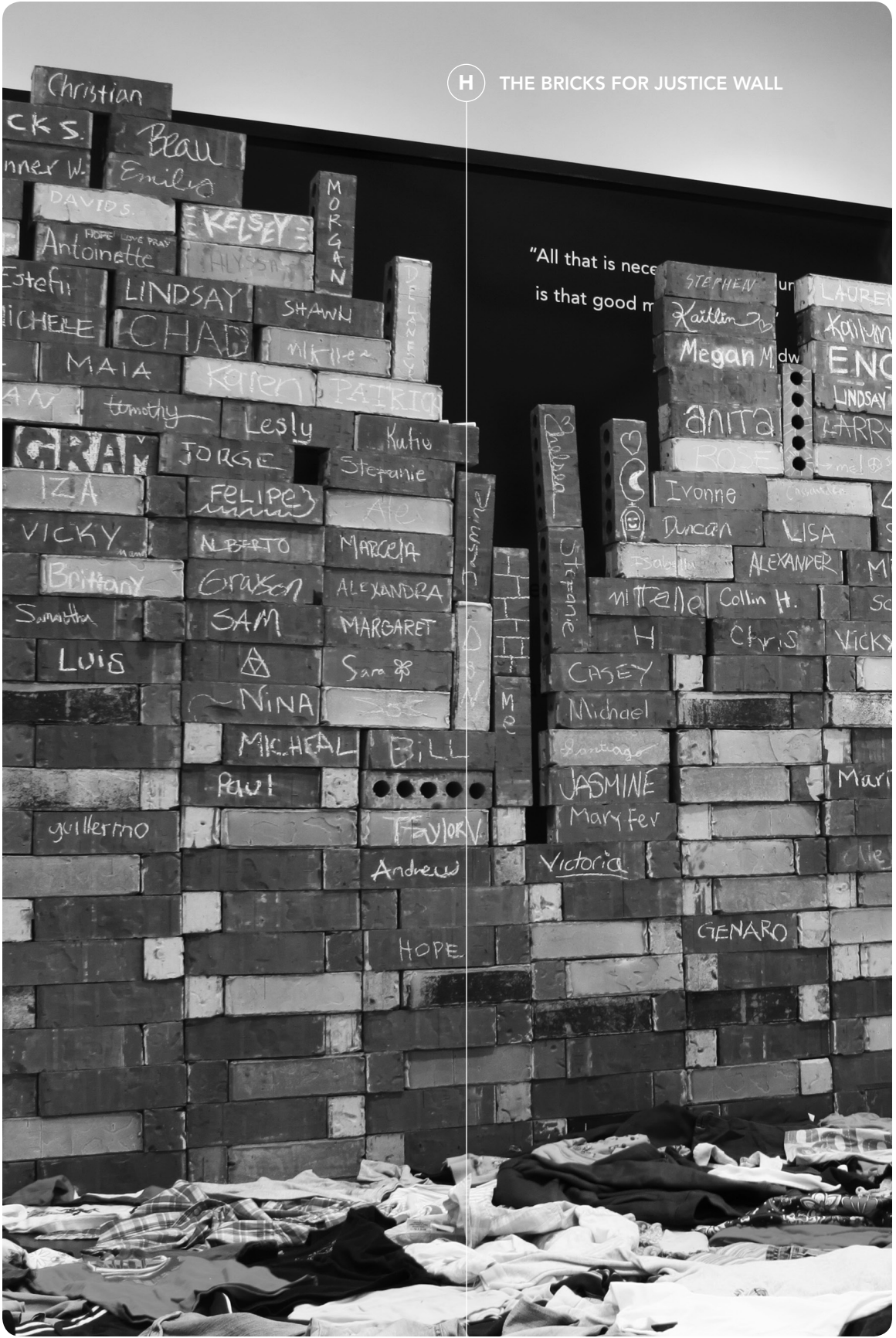

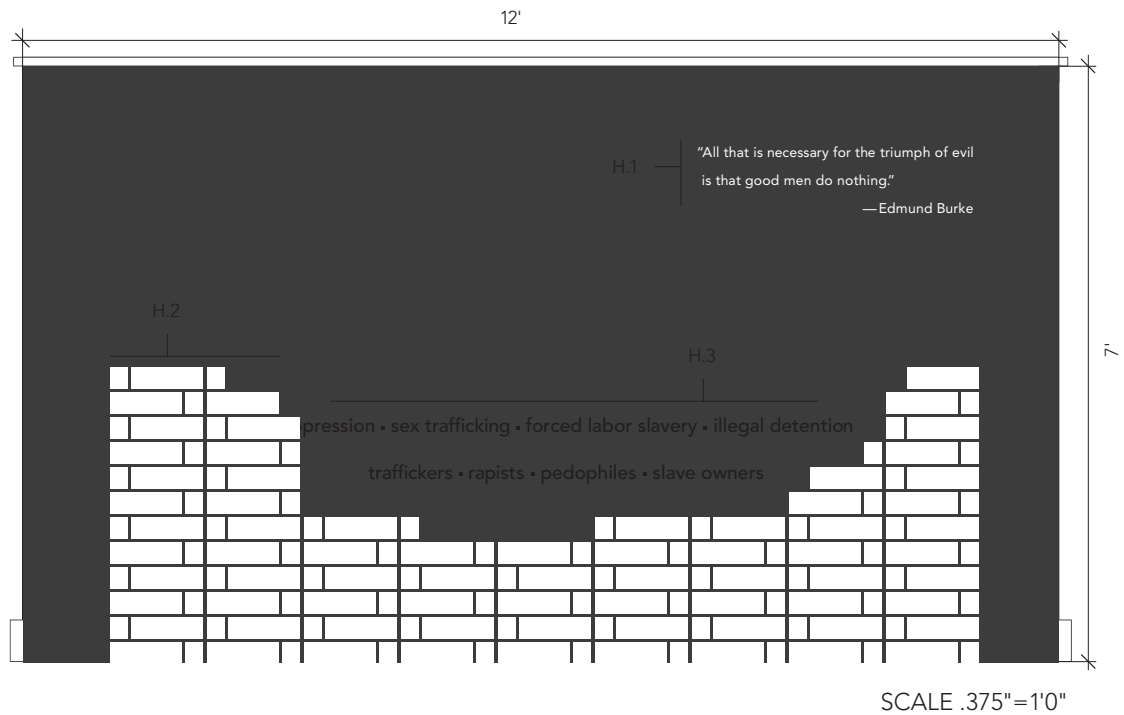

- H.1 Edmund Burke quote.** "...[All that is] necessary for the triumph of evil is for good men to do nothing" (Collins, 2003).  
Standard white matte vinyl, applied directly to painted matte black wall.  
Text set FL, Avenir Roman, 140/280 pt
- H.2 List of social problems addressed by IJM.** Standard black glossy vinyl, applied directly to painted matte black wall.  
Text set C, Avenir Roman, 193/600 pt
- H.3 Bricks for Justice Wall.** It was constructed with clay bricks signed with white chalk by participating visitors.



I FORMER VICTIMS



After her rescue, **Elizabeth** spent sometime in an aftercare center before returning to her family. Recently she completed her University degree in Geography.



**Stephen** falsely accused of robbing a bank and shooting a police officer in Kenya was released from jail thanks to LM's advocacy. Now he works for LM Kenya sharing the message of justice throughout the country.



Rescued from a brothel and spending couple of years in an aftercare home, **Katelyn** is now working toward her goal of someday owning an internet cafe and design Web sites for businesses.



**Ngejari** was a slave since the age of 12 in a brick kiln. After being rescued by LM and local authorities, he and his family own and operate their own brick kiln.



When **Claire's** husband passed away, she and her four young children were evicted from their own home. Thanks to LM lawyers she got her property back and set up a piggery, a sustainable source of income for her family.

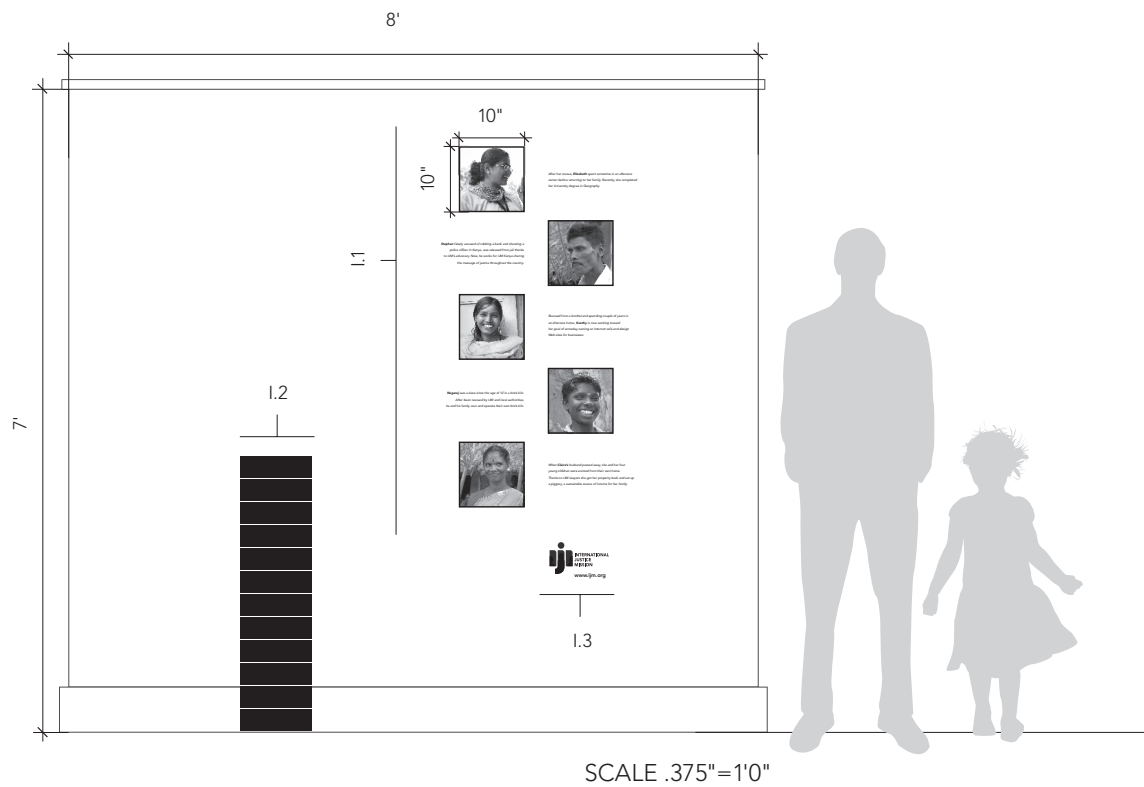

**I.1 Former victims.**

**I.2 Bricks for Justice wall.**

**I.3 IJM Signature.** Standard black matte vinyl, applied directly to painted white wall.

**EGD OUTCOME**

## Former Victims Schematics Detail



After her rescue, Elizabeth spent sometime in an aftercare center before returning to her family. Recently, she completed her University degree in Geography.

(IJM, 2006a).



Rescued from a brothel and spending couple of years in an after-care home, Kunthy is now working toward her goal of someday owning an Internet café and design Web sites for businesses.

(IJM, 2010c).



When Claire's husband passed away, she and her four young children were evicted from their own home. Thanks to IJM lawyers she got her property back and set up a piggery, a sustainable source of income for her family.

(IJM, 2010b).

**I.1 Former victims**

**EGD OUTCOME**

## Former Victims Schematics Detail (Continued)



Nagaraj was a slave since the age of 12 in a brick kiln. After been rescued by IJM and local authorities, he and his family own and operate their own brick kiln.

(IJM, 2006b).



Stephen, falsely accused of robbing a bank and shooting a police officer in Kenya, was released from jail thanks to IJM's advocacy. Now, he works for IJM Kenya sharing the message of justice throughout the country.

(IJM, 2010a).

**I.1 Former victims<sup>1</sup> (continued).**

Photographic ink-jet print, mounted flush on 5 mm 10" x 10" black Fome-Cor<sup>®</sup> board, against painted white wall.

Stories. Standard black matte vinyl, applied directly to painted white wall.

Text set FL and FR, Avenir Medium Oblique and Avenir Black Oblique, 32/64 pt

<sup>1</sup>Photographies and Former Victims' stories were provided and used with permission of Andy Hein, the Central South Director of Church Mobilization for IJM. Copyright 2012 by International Justice Mission. Adapted with permission.

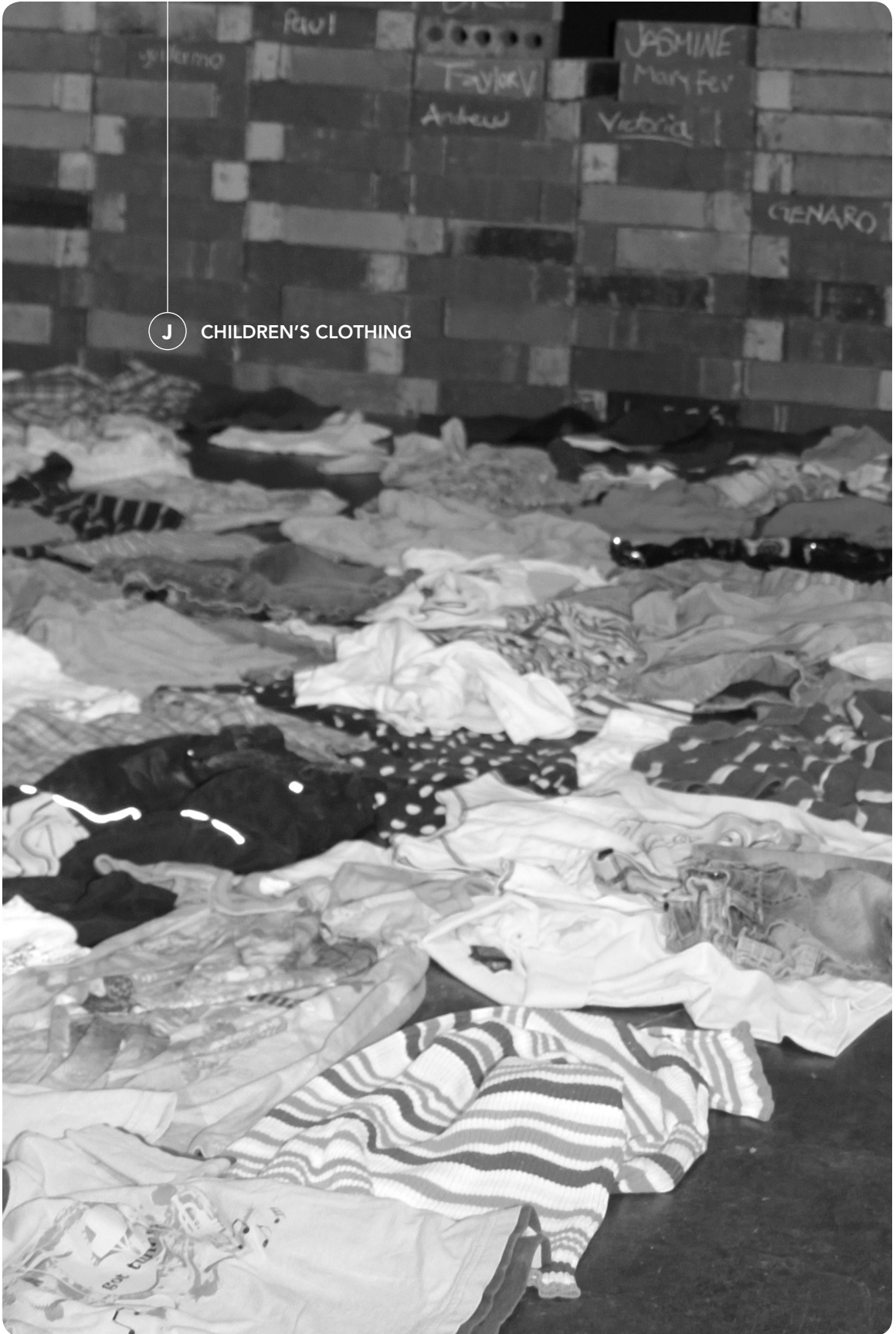

J CHILDREN'S CLOTHING

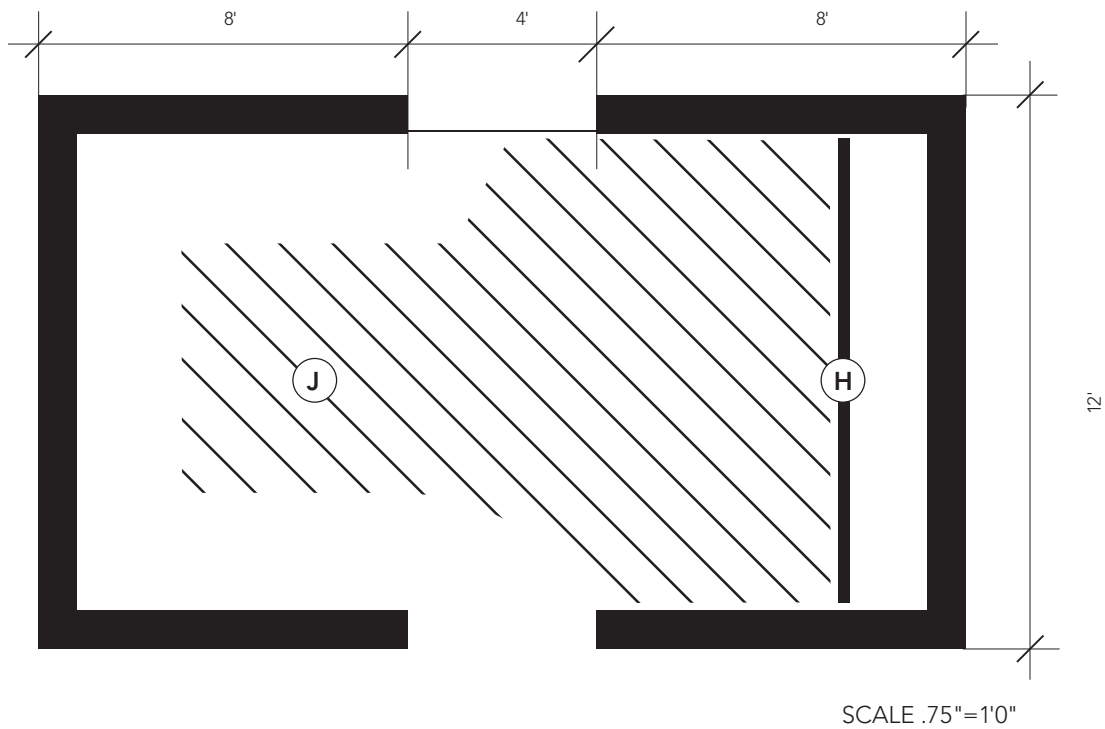

- H** THE BRICKS FOR JUSTICE WALL
- J** CHILDREN'S CLOTHING

**EGD OUTCOME**

Children's Clothing Schematics Detail



## APPENDIX B

### EXHIBITION PROMOTIONAL MATERIALS





# BRICKS FOR JUSTICE

A TRAVELING EXHIBITION  
FOR INTERNATIONAL JUSTICE MISSION,  
A HUMAN RIGHTS ORGANIZATION

GENARO S. RIVERO  
M.F.A. THESIS EXHIBITION

THE UNIVERSITY GALLERIES [2]  
Texas State University-San Marcos  
School of Art & Design  
Joan Cole Mitte Building  
Reception: March 22, 18:00 – 20:00 hrs  
Open: March 22 – 31, 09:00 – 22:00 hrs  
[bricksforjustice.com](http://bricksforjustice.com)



MARCH 22 2012

m . f . a .

18:00 HRS

## APPENDIX C

### EXHIBITION PHOTOGRAPHS



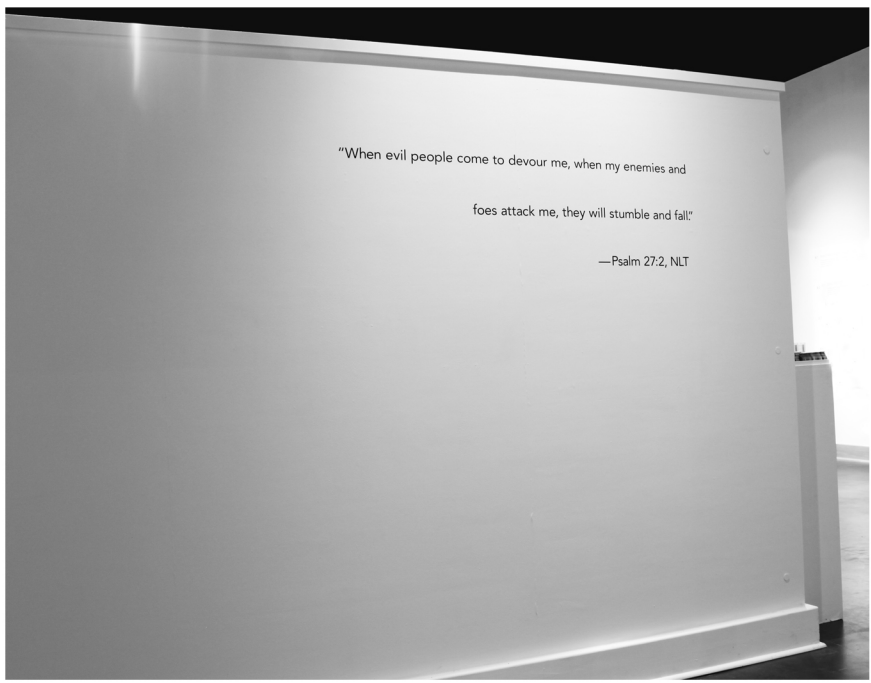

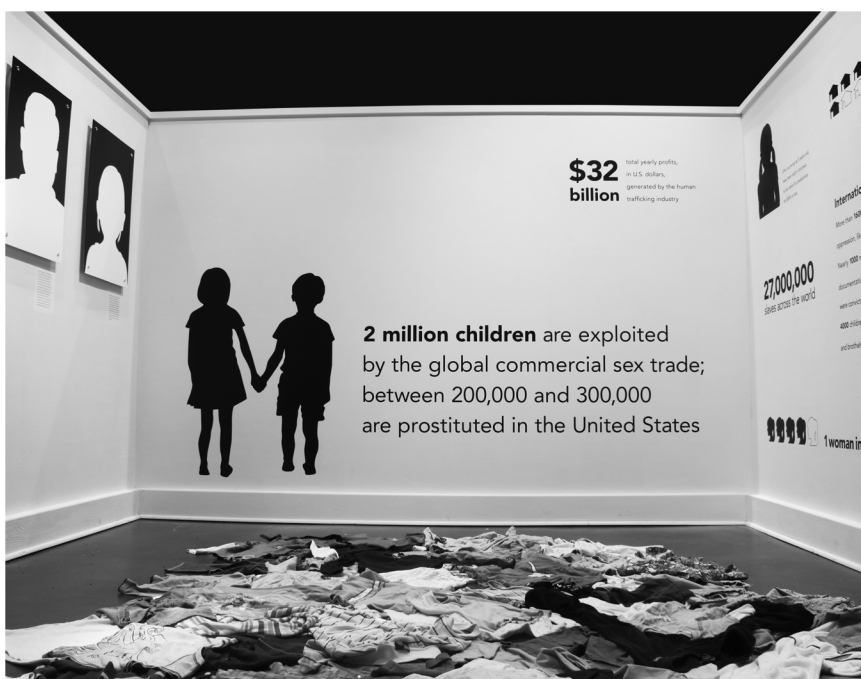

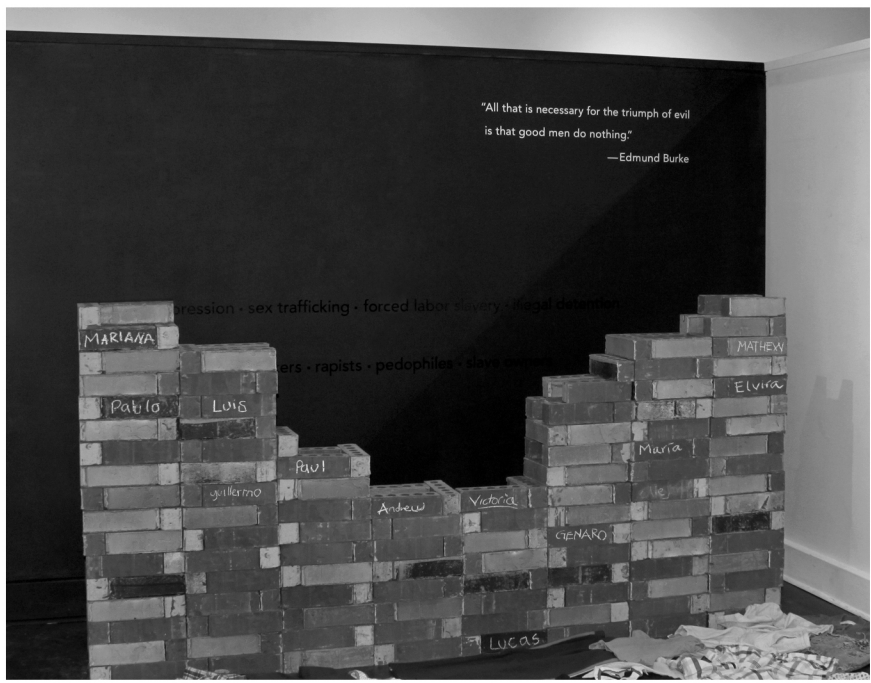

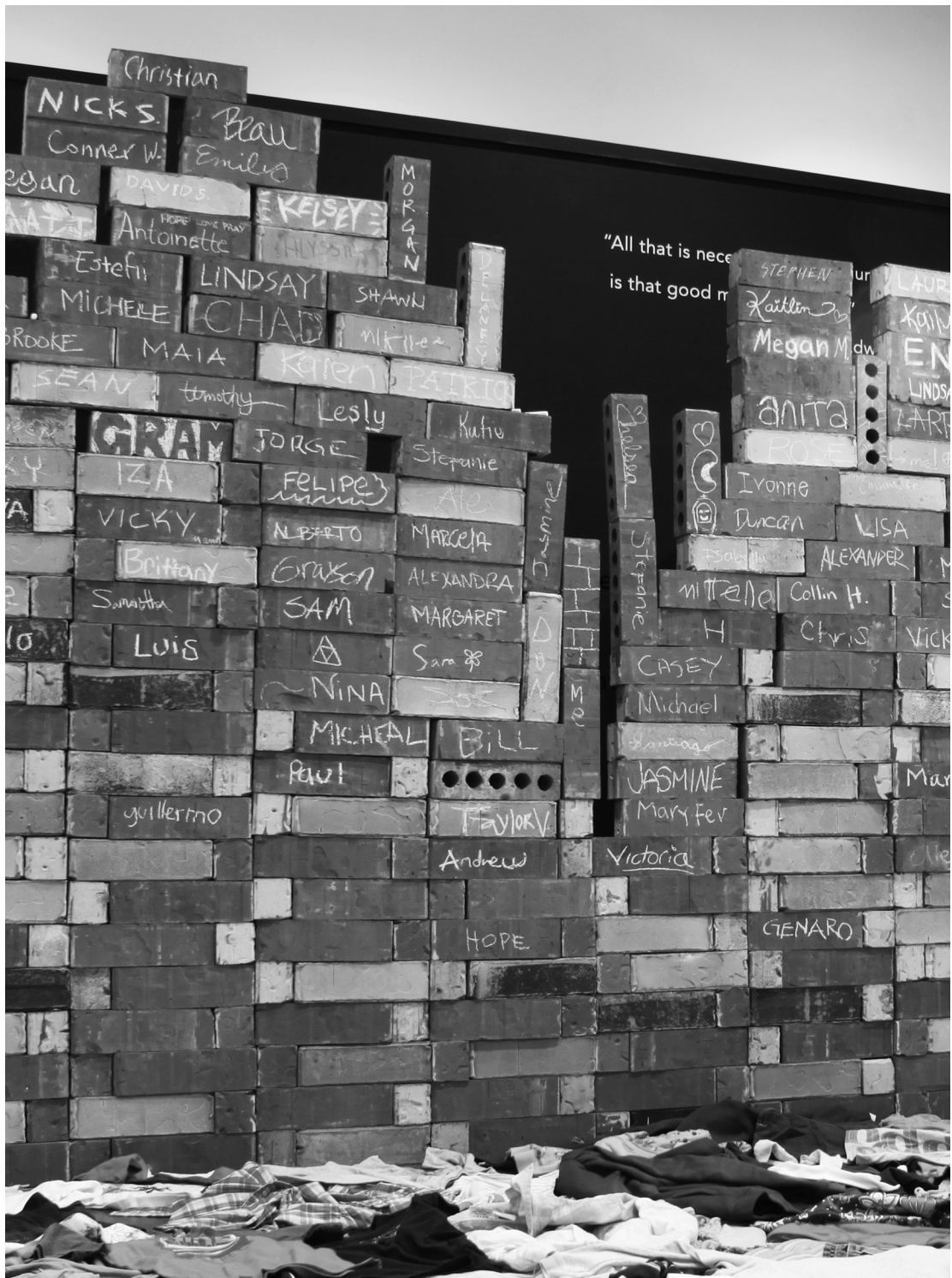

## REFERENCES

- Airey, D. (2010). *Logo design love: A guide to creating iconic brand identities*. Berkeley, CA: New Riders.
- Bales, K. (2004). *Disposable People*. Berkeley, CA: University of California Press, Ltd.
- Beate, A. (2008). *Forced labour and human trafficking: a handbook for labour inspectors*. Geneva, ILO: International Labour Office.
- Berger, C., Lorenc, J., & Skolnick, L. (2007). *What is exhibition design?* Mies, Switzerland: RotoVision SA.
- Bierut, M. (2007). *Seventy-nine short essays on design*. NY: Princeton Architectural Press.
- Collins. (2003). *Collins dictionary of quotations* [Electronic version]. Retrieved March 05, 2012, from <http://www.credoreference.com.libproxy.txstate.edu/entry/hcdquot/evil>
- Cranmer, J. & Zappaterra, Y. (2003). *Conscientious Objectives: Designing for an Ethical Message*. Mies, Switzerland: RotoVision SA.
- de Jong, M. & Kossmann, H. (2010). *Engaging spaces. Exhibition design explored*. (B. Nolan, Trans.) Minneapolis, MN: Amsterdam
- Eiseman, L. (2006). *Color: Messages and meanings, a Pantone® color resource*. Gloucester, MA: Hand Books Press.
- Glaser, M. (2006). Since then. In Bierut, M., Drenttel, W. & Heller, S. (Eds.), *Looking closer five. Critical writings on graphic design*. (pp. 144–148). New York: Allworth Press.
- Gobé, M. (2009). *Emotional branding: the new paradigm for connecting brands to people*. New York: Allworth Press.
- Haugen, G. A., & Hunter, G. (2005). *Terrify no more*. Nashville, TN: Thomas Nelson, Inc.
- Hong, H. [intrepidina]. (2010, October 10). *Milton Glaser 3* [Video file]. Retrieved from <http://vimeo.com/15847474>

- Hughes, P. (2010). *Exhibition Design*. London: Laurence King Publishing Ltd.
- International Justice Mission. (Producer). (2006a). *Sharon at Urbana* [conference video]. Retrieved March 12, 2012, from <https://www.facebook.com/video/video.php?v=514360151013>
- International Justice Mission. (2006b). *Fact Sheet. Nagaraj*. [Brochure].
- International Justice Mission. (2007). *Perpetrator Accountability: The Apocalypse Bar*. [Brochure].
- International Justice Mission. (2008). *International Justice Mission, from the field*. [Brochure].
- International Justice Mission. (2010a). *Fact Sheet. Illegal Detention*. [Brochure].
- International Justice Mission. (2010b). *Fact Sheet. Illegal Property Seizure*. [Brochure].
- International Justice Mission. (2010c). *Fact Sheet. Sexual Violence*. [Brochure].
- International Justice Mission. (2011). *2010 Annual Report*. [Brochure].
- International Justice Mission. (2012a). *Who we are*. Retrieved March 12, 2012, from <http://ijm.org/who-we-are>
- International Justice Mission. (2012b). *Celebrating thousand of lives transformed in 2011*. Retrieved March 12, 2012, from <http://ijm.org/content/celebrating-thousands-lives-transformed-2011>
- Kennedy, A. (Ed.). (2011). *Identify. Basic principles of identity design of the iconic trademarks of Chermayeff & Geismar*. New York: Print Publishing.
- Landa, R. (2006). *Designing brand experiences: Creating powerful integrated brand solutions*. Clifton Park, NY: Thomson Delmar Learning.
- Lindstrom, M. (2005). *Brand sense: Build powerful brands through touch, taste, smell, sight, and sound*. New York: Free Press.
- Lindstrom, M. (2008). *Buy•ology. Truth and lies about why we buy*. New York: Broadway Books.
- Lucas, G. (2006). *Guerrilla advertising. Unconventional brand communication*. London: Laurence King Publishing Ltd.
- Neumeier, M. (2007). *ZAG. The number-one strategy of high-performance brands*. New Riders: Berkeley, CA.
- Olins, W. (2008). *Wally Olins: The Brand Handbook*. United Kingdom: Thames & Hudson Inc.



- Pricken, M. (2008). *Creative advertising. Ideas and techniques from the world's best campaigns* (M. Whittall, Trans.). New York: Germany. (Original work published 2001)
- Renvoisé, P. & Morin, C. (2007). *Neuromarketing. Understanding the "buy buttons" in your customer's brain*. Nashville, TN: SalesBrain LLC.
- Stocklossa, U. (2007). *Advertising. New Techniques for Visual Seduction* (Wilson, D. Trans.). New York: Germany. (Original work published 2005)
- Twemlow, A. (2006). *What is graphic design for?* Mies, Switzerland: RotoVision SA.
- UN Department of Public Information. (2009). *UNiTE to End Violence Against Women*. [Brochure].
- Visocky O'Grady, J., & Visocky O'Grady, K. (2006). *A designer's research manual: Succeed in design by knowing your clients and what they really need*. Gloucester, MA: Rockport.
- Wheeler, A. (2006). *Designing brand identity: A complete guide to creating, building, and maintaining strong brands*. Hoboken, NJ: Wiley.

## VITA

Genaro Solís Rivero was born in Mexico City, Mexico, on September 9, 1974, the son of Virginia Rivero González and Genaro Solís Ramírez. After completing his work at Missouri Military Academy High School, he was admitted to the Communication Design program at Southwest Texas State University (now Texas State University-San Marcos). He received the degree of Bachelor of Fine Arts from Texas State in May 2002. During the following years, he was employed as graphic designer and Art Director with Equilibrio in Mexico City and in 2005; he co-founded Contrasto Group, a graphic design studio. In August 2009, he was admitted to the MFA program at Texas State University-San Marcos.

His communication design has been featured in the discipline's leading publications including *logoloune*, *logolounge Master Library*, and *Graphis*. Additionally, his communication design has received awards and been honored in national and international design competitions including Art Directors Club of Houston (ADCH), Creative Summit, Dallas Society of Visual Communications (DSVC), Good50x70, *Graphis*, *logolounge*, and *logolounge Master Library*.

Permanent Address:

genarosrivero@gmail.com

This thesis was typed by Genaro Solís Rivero.